

Concerto

design Enzo Berti

Description

Unexpected plays of curves, cuts and snaps make Concerto an unique table, a living sculpture for every day. The sophisticated technology hidden inside easily extends the top until 4,10 meters long.

Technical Details

Round extending table with aluminium runners.

Dimensions (LxPxH)

- Closed \varnothing cm 140x76
- Open cm 140x410x76
- n° 01 internal leave and n° 05 external leave cm 45

Finishings

Cod 01; Cod 02; Cod 03; Cod 04; Cod 05; Cod 06; Cod 07; Cod 08; Cod 09; Noce Canaletto; Palissandro

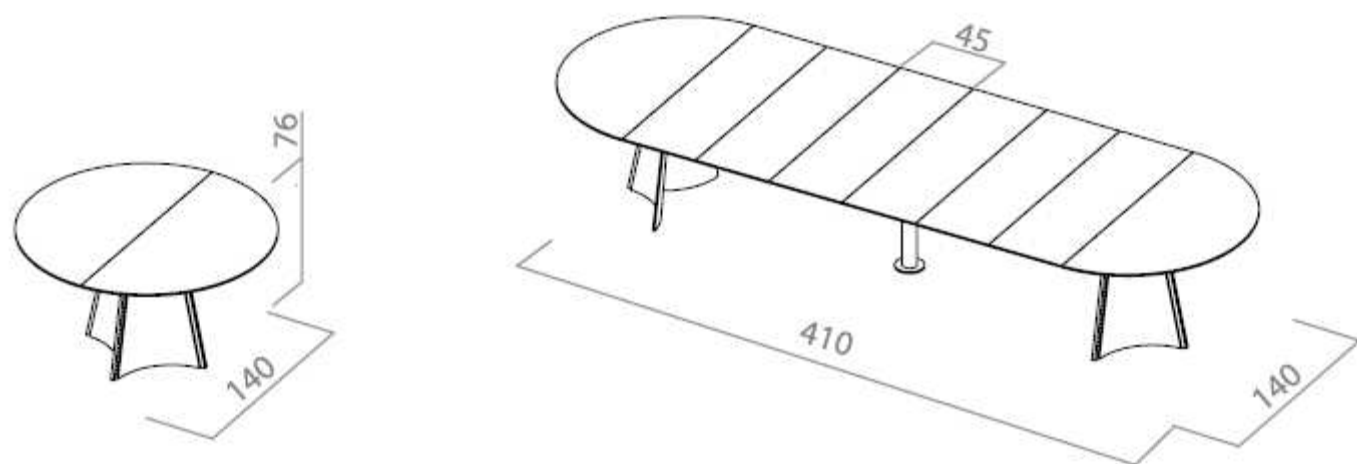



Cod. 01 - Frassino o Rovere
Cod. 01 - Ash or Oak



Cod. 05 - Frassino o Rovere
Cod. 05 - Ash or Oak



Cod. 09 - Bianco
Cod. 09 - White



Cod. 02 - Frassino sbiancato
Cod. 02 - Light Ash



Cod. 06 - Rovere sbiancato
Cod. 06 - Light Oak



Cod. 10 - Ciliegio
Cod. 10 - Cherry



Cod. 13 - Faggio
Cod. 13 - Beech

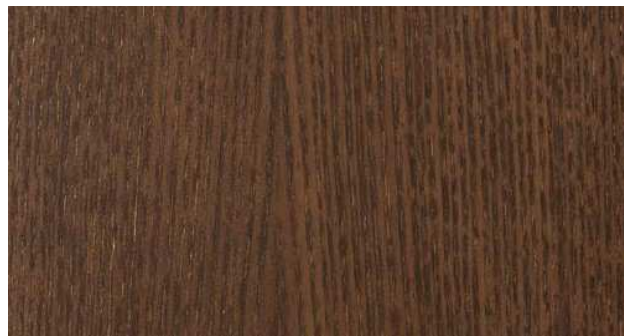

Cod. 03 - Frassino o Rovere
Cod. 03 - Ash or Oak



Cod. 07 - Rovere naturale
Cod. 07 - Natural Oak



Cod. 11 - Ciliegio
Cod. 11 - Cherry



Cod. 14 - Faggio
Cod. 14 - Beech



Cod. 04 - Frassino o Rovere
Cod. 04 - Ash or Oak



Cod. 08 - Frassino o Rovere
Cod. 08 - Ash or Oak



Cod. 12 - Ciliegio
Cod. 12 - Cherry



Cod. 15 - Faggio
Cod. 15 - Beech

I colori del campionario sono puramente indicativi e sono possibili differenze di tonalità tra una partita di produzione e l'altra. Il legno è un prodotto naturale: baffi, nodi, variazioni di colore e di poro sono le esclusive prove della sua naturale bellezza.

All sample colours are merely indicative and there may be differences in shade between one production lot and the another. Wood is a natural product: Any patches, knots, porous and shade variations are an exclusive proof of its natural beauty.