

### BASI A TERRA O IN APPOGGIO | FREE-STANDING OR SUPPORTED BASES

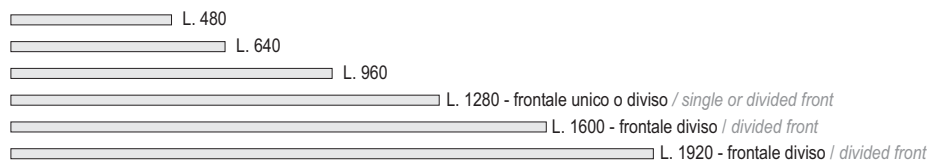

### BASI A TERRA, IN APPOGGIO O SOSPENSE | FREE-STANDING, SUPPORTED OR SUSPENDED BASES

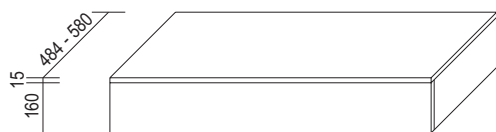
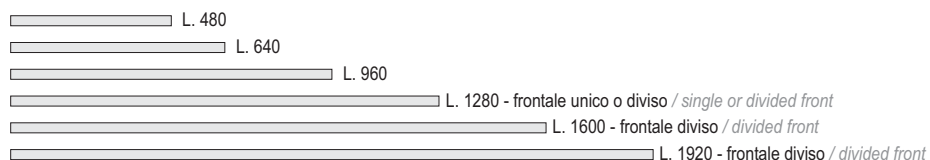
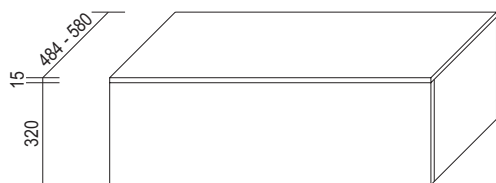

### ELEMENTI A TERRA, IN APPOGGIO O SOSPESI | FREE-STANDING, SUPPORTED OR SUSPENDED ELEMENTS

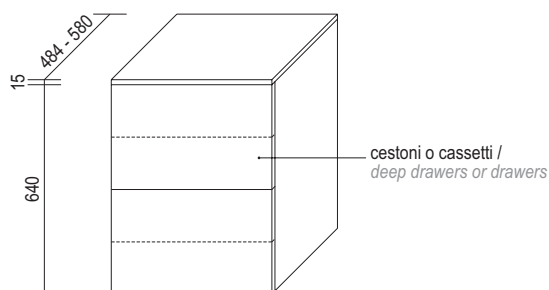
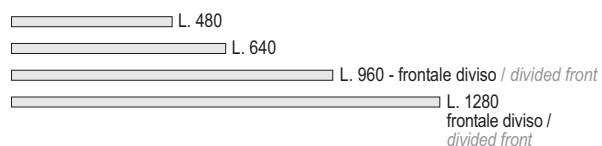
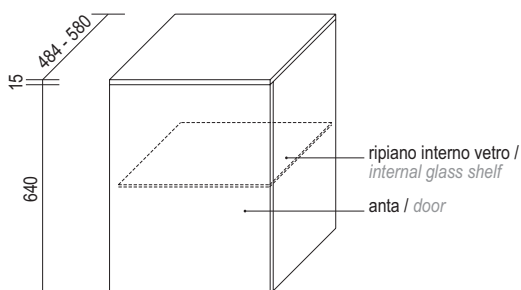

## CARATTERISTICHE DIMENSIONALI PENSILI SLIM | SLIM WALL UNITS DIMENSIONAL CHARACTERISTICS

### PENSILI ANTA BATTENTE A TERRA O SOSPESI | FREE-STANDING OR SUSPENDED HINGED-DOOR WALL UNITS

- I pensili hanno tutti i ripiani interni vetro ad eccezione di quelli con due ante che hanno ripiani vetro e legno ( i ripiani legno sono indicati con \*).  
 - The wall units all have glass internal shelves except those with two doors, which have glass and wood shelves (the wood shelves are indicated by \*).

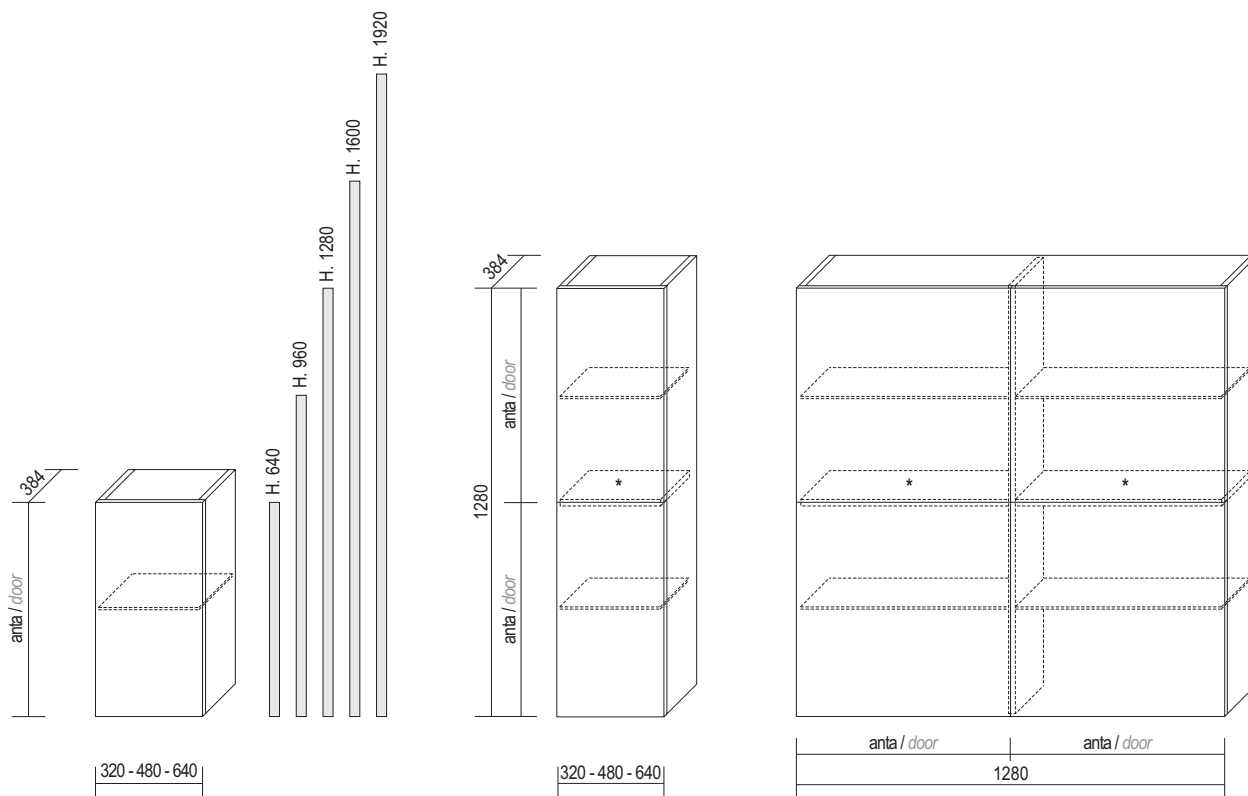

### RIBALTE PENSILI | SUSPENDED FLAP-DOOR WALL UNITS

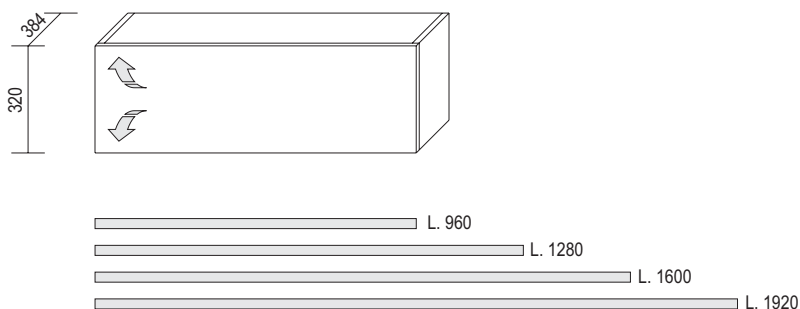

## CARATTERISTICHE TECNICHE SLIM | SLIM TECHNICAL CHARACTERISTICS

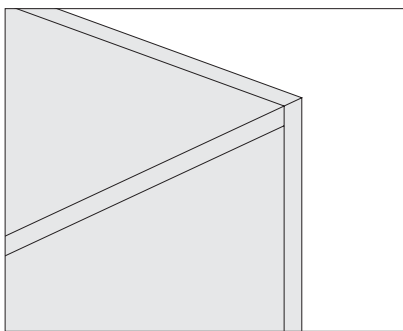

### STRUTTURE | STRUCTURES

Sono realizzate in pannelli di particelle di legno E1 spessore 20 mm, impiallacciati essenza oppure laccati colorati opachi o lucidi.  
*The structures are made of E1 wood particleboard with a thickness of 20 mm, wood veneered and open-pore painted, or lacquered in various matt or gloss colours.*

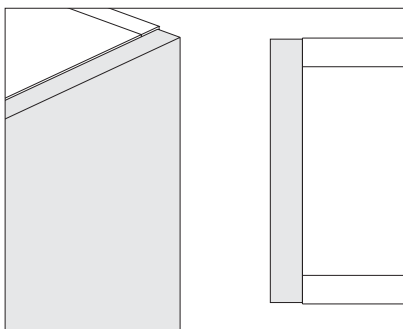

### FRONTALI LEGNO | WOOD FRONTS

Ante battenti, a ribalta, frontali cassetti e cestoni sono realizzati in pannelli di particelle di legno E1 spessore 20 mm, impiallacciati essenza oppure laccati colorati opachi o lucidi.

Sono di serie con apertura "push and pull" o a richiesta con maniglia.

*The hinged doors, flap-doors, drawer and deep drawer fronts are made of E1 wood particleboard with a thickness of 20 mm, wood veneered open-pore painted, or lacquered in various matt or gloss colours.*

*They are standard equipped with 'push and pull' opening or supplied with handles on request.*

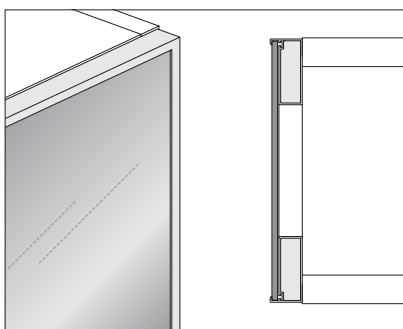

### ANTE TELAIO | FRAME DOORS

Sono composte da telai in alluminio finitura alluminio o brunito, e da vetro sp. 4 mm con varie finiture: vetro colorato, specchio bianco o bronzo, stopsol fumé e trasparente. I vetri stopsol fumé e trasparente lasciano intravedere il telaio sottostante. Le ante telaio sono battenti e a ribalta, disponibili solo con apertura "push and pull".

*The doors are composed of aluminium-finished or burnished aluminium frames and 4 mm thick glass with various finishes: coloured glass, white or bronze mirror, stopsol and transparent. The underlying frame can be seen through the stopsol and transparent glass. The frame doors can be hinged or flap-doors, with 'push and pull' opening.*

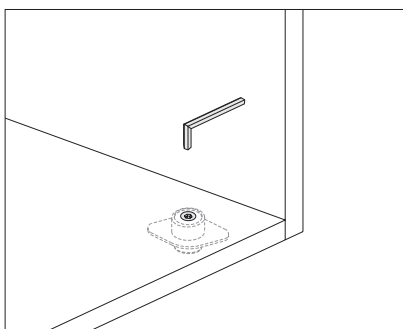

### REGOLAZIONE | ADJUSTMENT

Per le basi, gli elementi e i pensili a terra, la regolazione per la messa a bolla avviene tramite piedini livellatori, posizionati sul fondo e regolabili con chiave a brugola.

*For the free-standing bases, elements and wall units, the adjustment for levelling occurs through the levelling feet, positioned on the bottom and adjustable with hex key.*

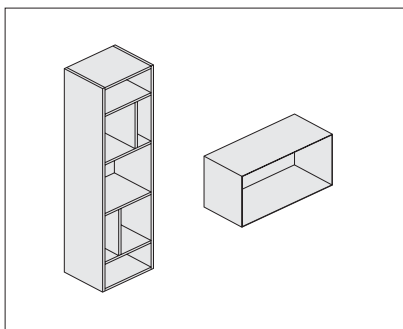

### ELEMENTI PENSILI A GIORNO | OPEN WALL UNITS

Gli elementi a giorno sono realizzati in pannelli di particelle di legno E1 spessore 15 mm, impiallacciati essenza oppure laccati colorati opachi o lucidi.

Sono sempre agganciati a muro e sono disponibili in tre dimensioni: 960 - 1280 - 1600 x 320 con una profondità di 362 mm.

*The open elements are made of E1 wood particleboard with a thickness of 15 mm, wood veneered and open-pore painted, or lacquered in various matt or gloss colours.*

*They are always attached to the wall and are available in three sizes: 960 - 1280 - 1600 x 320 with a depth of 362 mm.*

### ELEMENTI IN METALLO SOSPESI | SUSPENDED METAL ELEMENTS

Gli elementi a giorno in metallo sospesi sono realizzati in metallo verniciato laccato opaco. La schiena è in pannelli di particelle di legno E1 spessore 12 mm, laccata opaca dello stesso colore della struttura.

Sono sempre agganciati a muro e sono disponibili in due dimensioni: 320 - 640 x 320 con una profondità di 385 mm.

*The suspended metal open elements are made of lacquered matt painted metal. The back is made of E1 wood particleboard with a thickness of 12 mm, lacquered matt with the same colour as the structure.*

*They are always attached to the wall and are available in two sizes: 320 - 640 x 320 with a depth of 385 mm.*

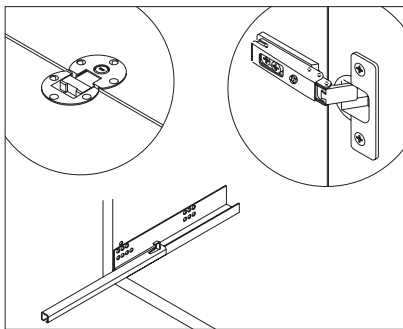

### SISTEMI DI APERTURA-CHIUSURA | OPENING AND CLOSING SYSTEM

Nello SLIM sono previsti tre tipologie di apertura: Anta battente - Ribalta - Cassetti/Cestoni.

Le ante battenti hanno due sistemi di apertura, push o maniglia.

Le ante di serie sono previste con apertura push (con cricchetto a spinta). Le ante con maniglia sono dotate di cerniere con sistema di chiusura ammortizzato (soft). Le ribalte con apertura verso il basso hanno cerniere piatte, mentre le ribalte con apertura verso l'alto utilizzano le stesse cerniere delle ante battenti; apertura di serie push o con maniglia.

I cassetti/cestoni in battuta di serie sono dotati di guide con apertura push e sincronizzatore che ne facilita l'apertura.

I cassetti/cestoni con maniglia sono dotati di guide con sistema di chiusura ammortizzato (soft).

*For the system with SLIM side panels, three opening systems are provided: Hinged door - Flap door - Drawers.*

*The hinged doors have two opening systems, push or handle.*

*The standard doors are provided with a push opening (with push click). The doors with handle are equipped with hinges with dampened closure (soft). The flap-doors with downward opening have flat hinges, while those with upward opening use the same hinges as the hinged doors; available with standard push opening or handle.*

*The standard jutting drawers are equipped with guides with push opening and synchronizer which makes them easier to open.*

*The drawers with handle are equipped with guides with dampened closure system (soft).*

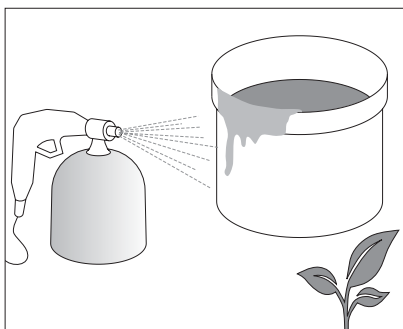

### VERNICI | PAINTS

Le vernici utilizzate sono a basso residuo secco e atossiche. Per le essenze e i laccati opachi il ciclo di verniciatura è ad acqua, mentre per i laccati lucidi a solvente.

Il tipo di finitura per l'essenza è a poro aperto.

*The paints employed are low-residue ones and atoxic. For the wood and lacquered matt finishes, water-borne paints are used.*

*For the lacquered gloss finishes solvent-based paints are used. The wood finish is an open-pore transparent one.*

### TOLLERANZE | TOLERANCES

Le parti con finitura in essenza possono subire nel tempo variazioni di colore dovute alla luce, all'umidità e al passare del tempo.

Esistono anche dei margini di tolleranza dovuti a variazione di prodotto per le finiture laccate.

In caso di un completamento successivo dell'ordine, non si garantisce la perfetta eguaglianza di colori con la composizione originaria.

*The parts with wood finish may change colour over time due to exposure to light and humidity as well as the passing of time.*

*There are also tolerance margins due to product variation for lacquered finishes.*

*In the event of a subsequent order, it is not guaranteed that the colours will match perfectly with the original composition.*

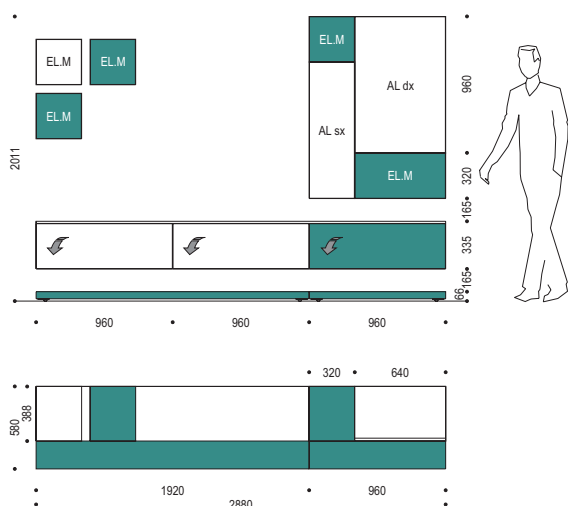

### COMPOSIZIONE | COMPOSITION 1

L. 2880 H. 2011 P.|D. 580

- PANCHE P. 580 lacc. opaco verde petrolio | lacq. matt petrol green  
*BENCHES D.580*
- RIBALTE PENSILI P.388 lacc. opaco bianco | lacq. matt white 9003  
*FLAP-DOOR WALL UNITS D.388* lacc. opaco verde petrolio | lacq. matt petrol green
- PENSILI ANTA BATT. P.384 L.320-640 lacc. opaco bianco | lacq. matt white 9003  
*HINGED DOOR WALL UNITS D.384 L.320-640*
- EL. IN METALLO SOSPESI P.385 L.320-640 lacc. opaco bianco | lacq. matt white 9003  
*SUSPENDED METAL ELEMENTS D.385* lacc. opaco verde petrolio | lacq. matt petrol green

DESIGN: Arch. Massimo Rosa - imagodesign

BASI SOSPESI ED ELEMENTI PENSILI CHIUSI E A GIORNO CARATTERIZZANO LA PARETE SLIM ABBINANDO IL BIANCO OPACO AL GRINTOSO VERDE PETROLIO. GLI ELEMENTI A RIBALTA DELLA COLLEZIONE GIORNO SLIM RISULTANO COMODI E CAPIENTI, POSSONO AVERE L'APERTURA PUSH AND PULL MANTENENDO UN'ESTETICA SOBRIA E MINIMALE.

APERTURA DEI FRONTALI "PUSH AND PULL".

A RICHIESTA PUÒ ESSERE INSERITA LA MANIGLIA IN FINITURA TITANIO, BIANCA O VERNICIATA COLORE A CARTELLA.

*SUSPENDED BASE CABINETS AND WALL CABINETS WITH AND WITHOUT FRONTS CHARACTERIZE THIS BEAUTIFUL SLIM WALL SOLUTION, WHICH COMBINES MATT WHITE WITH PETROLEUM GREEN.*

*THE CABINETS WITH FLAP FRONTS OF THE SLIM COLLECTION ARE PRACTICAL AND SPACIOUS. THEY ARE ALSO AVAILABLE WITH PUSH & PULL FRONTS, WHICH ADD TO A CLEAN, MINIMAL STYLE.*

*FRONTS WITH "PUSH AND PULL" OPENING.*

*ON REQUEST CAN BE INCLUDED THE HANDLE IN TITANIUM AND WHITE FINISH, OR PAINTED IN THE CARD COLOURS.*

## COMPOSIZIONI SLIM | SLIM COMPOSITION



### COMPOSIZIONE | COMPOSITION 2

L. 3840 H. 1570 P./D. 484

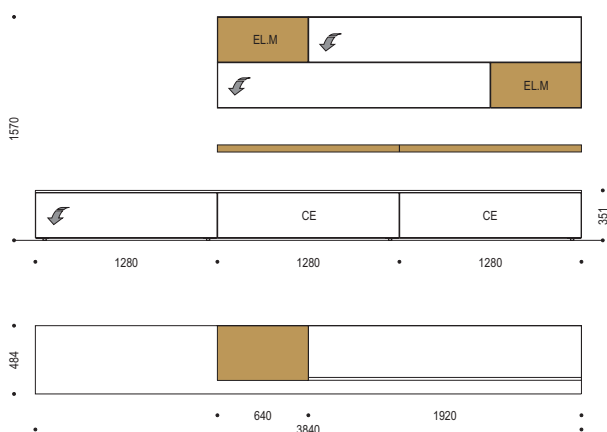

- BASI A TERRA P.484  
FREE-STANDING BASES D.484
- RIBALTE PENSILI P.384  
FLAP-DOOR WALL UNITS D.384
- MENSOLE SP.50  
SHELVES TH.50
- EL. IN METALLO SOSPESI P.385 L.640  
SUSPENDED METAL ELEMENTS D.385 L.640

lacc. opaco bianco | lacq. matt white 9003

lacc. opaco bianco | lacq. matt white 9003

lacc. opaco senape | lacq. matt mustard 1024

lacc. opaco senape | lacq. matt mustard 1024

DESIGN: Arch. Massimo Rosa - imagodesign

I PENSILI A RIBALTA ASSOCIATI AGLI ELEMENTI A GIORNO METALLICI CREANO GIOCHI DI VUOTI E DI PIENI ADATTI AD AMBIENTI RICERCATI ED ELEGANTI. LE MENSOLE E IL PIANO D'APPOGGIO AIUTANO AD AUMENTARE LA PERSONALITÀ DELLA COMPOSIZIONE GIORNO RENDENDO L'AMBIENTE ACCOGLIENTE E PIACEVOLE. APERTURA DEI FRONTALI "PUSH AND PULL". A RICHIESTA PUÒ ESSERE INSERITA LA MANIGLIA IN FINITURA TITANIO, BIANCA O VERNICIATA COLORE A CARTELLA.

WALL CABINETS WITH FLAP FRONTS ARE MATCHED WITH METAL OPEN CABINETS, CREATING AN ALTERNATION OF OPEN AND CLOSED COMPARTMENTS THAT ENHANCES THE SOPHISTICATED ELEGANCE OF THIS FURNISHING COMBINATION.

THE SHELVES AND THE REST SURFACE LEND CHARACTER TO THIS FURNISHING COMBINATION FOR THE LIVING AREA, TURNING THE ROOM INTO A PLEASANT AND WELCOMING ENVIRONMENT.

FRONTS WITH "PUSH AND PULL" OPENING.

ON REQUEST CAN BE INCLUDED THE HANDLE IN TITANIUM AND WHITE FINISH, OR PAINTED IN THE CARD COLOURS.

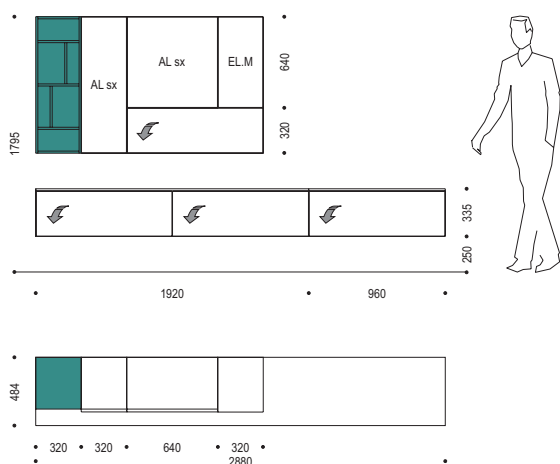

### COMPOSIZIONE | *COMPOSITION 3*

L. 2880 H. 1795 P./D. 484

- BASI SOSPESE P.484 lacc. opaco bianco | lacq. matt white 9003  
*SUSPENDED BASES D.484*
- PENSILI ANTA BATT. P.384 L.320-640 lacc. opaco bianco | lacq. matt white 9003  
*HINGED DOOR WALL UNITS D.384 L.320-640*
- RIBALTA PENSILE P.384 L.960 lacc. opaco bianco | lacq. matt white 9003  
*FLAP-DOOR WALL UNITS D.384 L.960*
- EL. PENSILI A GIORNO P.362 L.320 lacc. opaco verde petrolio | lacq. matt petrol green  
*OPEN WALL UNITS D.362 L.320*
- EL. IN METALLO SOSPESO P.385 L.320 lacc. opaco bianco | lacq. matt white 9003  
*SUSPENDED METAL ELEMENTS D.385 L.320*

DESIGN: Arch. Massimo Rosa - imagodesign

LA MODULARITA' DEGLI ELEMENTI DELLA COLLEZIONE SLIM PERMETTE DI AFFIANCARE ELEMENTI DIVERSI RICONDUCENDOSI A FIGURE GEOMETRICHE PURE. INTERESSANTE L'ELEMENTO LIBRERIA PER PICCOLI OGGETTI, DVD E CD. APERTURA DEI FRONTALI "PUSH AND PULL". A RICHIESTA PUÒ ESSERE INSERITA LA MANIGLIA IN FINITURA TITANIO, BIANCA O VERNICIATA COLORE A CARTELLA.

*THE SLIM COLLECTION IS SO MODULAR THAT YOU CAN MATCH CABINETS WITH DIFFERENT GEOMETRIC SHAPES. TAKE A CLOSER LOOK AT THE CD/DVD STORAGE SYSTEM, WHICH CAN ALSO HOLD BOOKS AND SMALL OBJECTS. FRONTS WITH "PUSH AND PULL" OPENING. ON REQUEST CAN BE INCLUDED THE HANDLE IN TITANIUM AND WHITE FINISH, OR PAINTED IN THE CARD COLOURS.*

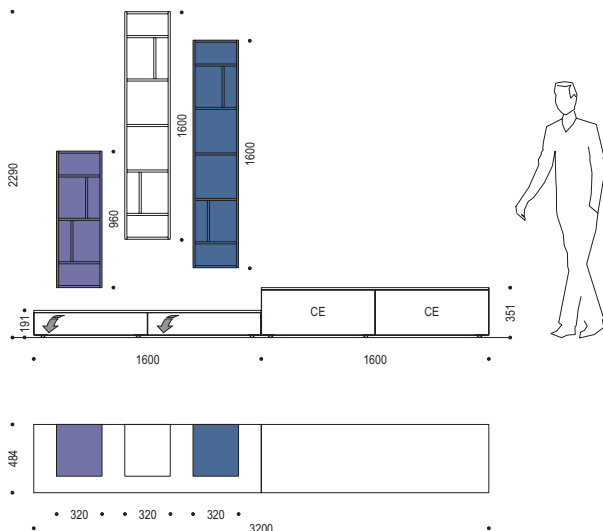

### COMPOSIZIONE | *COMPOSITION 4*

L. 3200 H. 2290 P. | D. 484

- BASI A TERRA P.484  
*FREE-STANDING BASES D.484*
- EL. PENSILI A GIORNO P.362 L.320  
*OPEN WALL UNITS D.362 L.320*

lacc. lucido bianco | *lacq. gloss white 9003*

lacc. lucido bianco | *lacq. gloss white 9003*

lacc. lucido viola | *lacq. gloss violet 4005*

lacc. lucido blu lavanda | *lacq. gloss lavender blu 5014*

DESIGN: Arch. Massimo Rosa - *imagodesign*

I PENSILI LIBRERIA POSIZIONATI IN VERTICALE DIVENTANO VALIDI E CAPIENTI CONTENITORI.

IL GIOCO DEL COLORE PERMETTE DI SBIZZARRIRSI ADATTANDOLI AL GUSTO PERSONALE E ALLE MODE. IN QUESTO CASO IL BIANCO LUCIDO DELLE BASI E' ABBINATO AL LUCIDO VIOLA E AL LUCIDO LAVANDA DEGLI ELEMENTI VERTICALI.

APERTURA DEI FRONTALI "PUSH AND PULL".

A RICHIESTA PUÒ ESSERE INSERITA LA MANIGLIA IN FINITURA TITANIO, BIANCA O VERNICIATA COLORE A CARTELLA.

*THESE BEAUTIFUL VERTICAL BOOKCASES CAN ALSO BE USED AS PRACTICAL OPEN STORAGE CABINETS.*

*CHOOSE FROM A VARIETY OF COLOURS AND FIND THE CHROMATIC COMBINATION THAT BEST SUITS YOUR PERSONAL STYLE. IN THIS CASE, GLOSSY WHITE BASE CABINETS ARE MATCHED WITH GLOSSY PURPLE AND GLOSSY LAVENDER VERTICAL WALL CABINETS.*

*FRONTS WITH "PUSH AND PULL" OPENING.*

*ON REQUEST CAN BE INCLUDED THE HANDLE IN TITANIUM AND WHITE FINISH, OR PAINTED IN THE CARD COLOURS.*



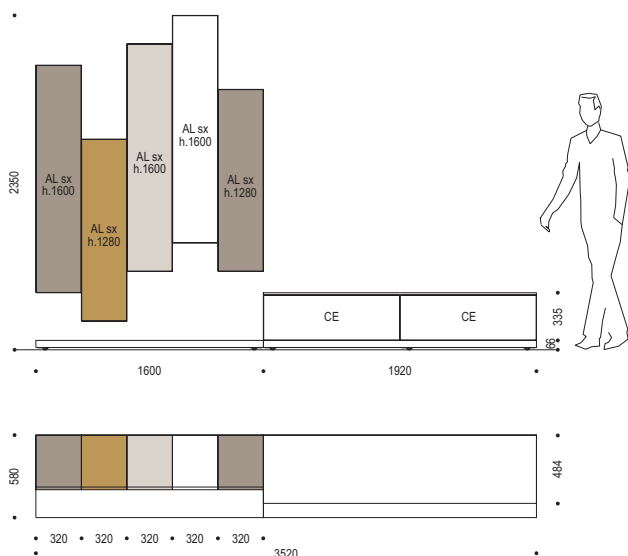

### COMPOSIZIONE | COMPOSITION 5

L. 3520 H. 2350 P./D. 580

- PANCHE P. 580  
BENCHES D.580
  - BASI A TERRA P.484  
FREE-STANDING BASES D.484
  - PENSILI ANTA BATTENTE P.384 L.320  
HINGED DOOR WALL UNITS D.384 L.320
- lacc. lucido bianco | lacq. gloss white 9003  
lacc. lucido bianco | lacq. gloss white 9003  
lacc. lucido bianco | lacq. gloss white 9003  
lacc. lucido tortora | lacq. gloss dove grey  
lacc. lucido senape | lacq. gloss mustard 1024  
lacc. lucido corda | lacq. gloss rope colour

DESIGN: Arch. Massimo Rosa - imagodesign

I PENSILI SFALSATI E REALIZZATI ABBINANDO INSIEME VARI COLORI CREANO UN FORTE ELEMENTO GEOMETRICO SULLA PARETE.  
LE BASI BIANCHE E TUTTA LA COMPOSIZIONE È REALIZZATA NELLA FINITURA LACCATA LUCIDA.  
APERTURA DEI FRONTALI "PUSH AND PULL".  
A RICHIESTA PUÒ ESSERE INSERITA LA MANIGLIA IN FINITURA TITANIO, BIANCA O VERNICIATA COLORE A CARTELLA.

STAGGERED HEIGHTS IN THE WALL CABINETS CREATE A STRONG GEOMETRIC PATTERN ON THE WALL.  
GLOSSY WHITE BASE CABINETS ARE MATCHED WITH WALL CABINETS IN A VARIETY OF GLOSSY COLOURS.  
FRONTS WITH "PUSH AND PULL" OPENING.  
ON REQUEST CAN BE INCLUDED THE HANDLE IN TITANIUM AND WHITE FINISH, OR PAINTED IN THE CARD COLOURS.



### COMPOSIZIONE | COMPOSITION 6

L. 3200 H. 1880 P.|D. 388

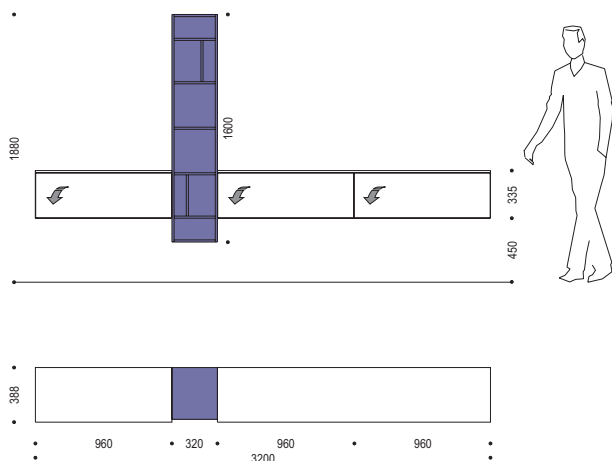

- RIBALTE PENSILI P.388 lacc. lucido bianco | lacq. gloss white 9003  
FLAP-DOOR WALL UNITS D.388
- EL. PENSILE A GIORNO P.362 L.320 lacc. lucido viola | lacq. gloss violet 4005  
OPEN WALL UNITS D.362 L.320

DESIGN: Arch. Massimo Rosa - imagodesign

LINEE PURE E RIGOROSE, VOLUMI CHIARI E RICONOSCIBILI, ABBINAMENTO ACCATTIVANTE TRA BIANCO LUCIDO E VIOLA SONO SOLO ALCUNI ARGOMENTI DI QUESTA COMPOSIZIONE.

APERTURA DEI FRONTALI "PUSH AND PULL".

A RICHIESTA PUÒ ESSERE INSERITA LA MANIGLIA IN FINITURA TITANIO, BIANCA O VERNICIATA COLORE A CARTELLA.

*PURE AND RIGOROUS LINES, CLEAR VOLUMES AND AN EYE-CATCHING COMBINATION OF GLOSSY WHITE AND GLOSSY PURPLE ARE JUST SOME OF THE DISTINGUISHING FEATURES OF FURNISHING COMBINATION.*

*FRONTS WITH "PUSH AND PULL" OPENING.*

*ON REQUEST CAN BE INCLUDED THE HANDLE IN TITANIUM AND WHITE FINISH, OR PAINTED IN THE CARD COLOURS.*

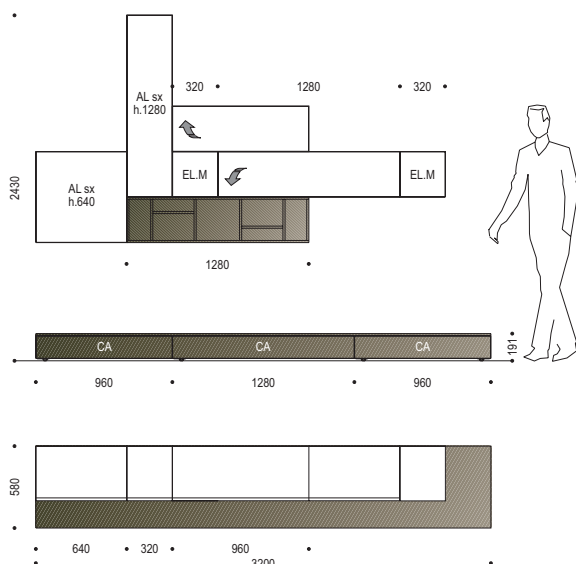

### COMPOSIZIONE | COMPOSITION 7

L. 3200 H. 2430 P./D. 580

- BASI A TERRA P.580 rovere moro | oak in mahogany finish  
*FREE-STANDING BASES D.580*
- PENSILI ANTA BATT. P.384 L.320-640 lacc. lucido bianco | lacq. gloss white 9003  
*HINGED DOOR WALL UNITS D.384 L.320-640*
- RIBALTE PENSILI P.384 L.960-1280 lacc. lucido bianco | lacq. gloss white 9003  
*FLAP-DOOR WALL UNITS D.384 L.960-1280*
- EL. PENSILE A GIORNO P.362 L.1280 rovere moro | oak in mahogany finish  
*OPEN WALL UNITS D.362 L.1280*
- EL. IN METALLO SOSPESI P.385 L.320 lacc. opaco bianco | lacq. matt white 9003  
*SUSPENDED METAL ELEMENTS D.385 L.320*

DESIGN: Arch. Massimo Rosa - imagodesign

L'ELEGANZA DEL ROVERE MORO MIXATO CON IL BIANCO LUCIDO DEI PENSILI CARATTERIZZA LA COMPOSIZIONE, DOVE OGNI ELEMENTO TROVA LA GIUSTA COLLOCAZIONE COME IN UN GIOCO DI INCASTRI.  
APERTURA DEI FRONTALI "PUSH AND PULL".  
A RICHIESTA PUÒ ESSERE INSERITA LA MANIGLIA IN FINITURA TITANIO, BIANCA O VERNICIATA COLORE A CARTELLA.

*ELEGANT DARK OAK IS COMBINED WITH GLOSSY WHITE IN THIS FURNISHING COMBINATION, WHERE EVERY SINGLE COMPONENT FINDS THE RIGHT PLACE AS IN A PUZZLE.*

*FRONTS WITH "PUSH AND PULL" OPENING.*

*ON REQUEST CAN BE INCLUDED THE HANDLE IN TITANIUM AND WHITE FINISH, OR PAINTED IN THE CARD COLOURS.*

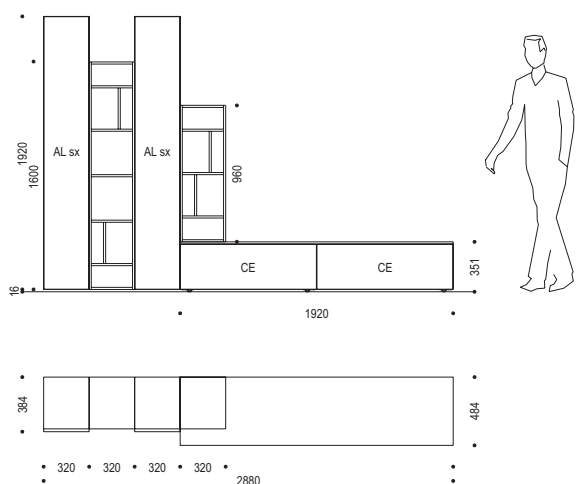

### COMPOSIZIONE | COMPOSITION 8

L. 2880 H. 1936 P./D. 484

- BASIA TERRA P.484 lacc. opaco bianco | lacq. matt white 9003  
*FREE-STANDING BASES D.484*
- PENSILI ANTA BATT. P.384 L.320 lacc. opaco bianco | lacq. matt white 9003  
*HINGED DOOR WALL UNITS D.384 L.320*
- EL. PENSILI A GIORNO P.362 L.320 lacc. opaco bianco | lacq. matt white 9003  
*OPEN WALL UNITS D.362 L.320*

DESIGN: Arch. Massimo Rosa - imagodesign

ELEMENTI PASSACAVI ED ACCESSORI DI OGNI GENERE ARRICCHISCONO LA COLLEZIONE SLIM VENENDO INCONTRO ALLE PIU' MODERNE ESIGENZE D'ARREDO. LA COMPOSIZIONE "8" È SEMPLICE, CAPIENTE ED ESSENZIALE. APERTURA DEI FRONTALI "PUSH AND PULL". A RICHIESTA PUÒ ESSERE INSERITA LA MANIGLIA IN FINITURA TITANIO, BIANCA O VERNICIATA COLORE A CARTELLA.

*PRACTICAL CABLE ORGANIZERS AND LOTS OF DIFFERENT ACCESSORIES OF THE SLIM COLLECTION WILL MEET ANY TYPE OF MODERN FURNISHING REQUIREMENTS. FURNISHING COMBINATION "8" IS SIMPLE AND ESSENTIAL, YET PARTICULARLY SPACIOUS. FRONTS WITH "PUSH AND PULL" OPENING. ON REQUEST CAN BE INCLUDED THE HANDLE IN TITANIUM AND WHITE FINISH, OR PAINTED IN THE CARD COLOURS.*

## COMPOSIZIONI SLIM | SLIM COMPOSITION



### COMPOSIZIONE | COMPOSITION 10

L. 3550 H. 1560 P. | D. 362

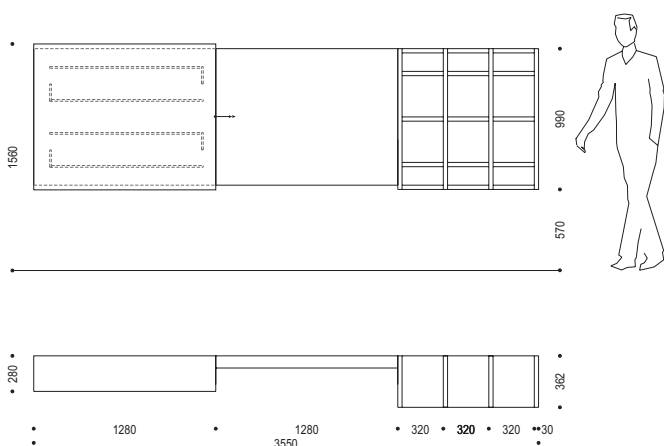

- PORTA TV SOSPESO P.100 lacc. lucido bianco | lacq. gloss white 9003  
*SUSPENDED TV STAND D.100*
- PANN. SOSPESO C/MENSOLE P.250 lacc. lucido bianco | lacq. gloss white 9003  
*SUSPENDED PANELS WITH SHELVES D.250*
- ANTA SCORREVOLE PER PORTA TV P.280 lacc. lucido bianco | lacq. gloss white 9003  
*SLIDING DOOR FOR TV STAND D.280*
- LIBRERIA SOSPESA SPEED P.362 lacc. lucido bianco | lacq. gloss white 9003  
*SPEED SUSPENDED BOOKCASE D.362*

DESIGN: Arch. Massimo Rosa - imagodesign

IL PARTICOLARE ELEMENTO CON L'ANTA SCORREVOLE PUO' COPRIRE LA TELEVISIONE OPPURE LE MENSOLE LATERALI PORTA DVD.  
IL TUTTO ABBINATO ALLA LIBRERIA SOSPESA CAPIENTE E STUDIATA PER ACCOGLIERE LIBRI O PICCOLI OGGETTI.  
APERTURA DEI FRONTALI "PUSH AND PULL".  
A RICHIESTA PUO' ESSERE INSERITA LA MANIGLIA IN FINITURA TITANIO, BIANCA O VERNICIATA COLORE A CARTELLA.

*THE BEAUTIFUL WALL CABINET WITH A SLIDING FRONT CAN HIDE THE TV OR THE SIDE SHELVES AND THE DVD ORGANIZER.  
THE SPACIOUS BOOKCASE CONTAINS LOTS OF STORAGE SPACE FOR BOOKS AND SMALL OBJECTS.  
FRONTS WITH "PUSH AND PULL" OPENING.  
ON REQUEST CAN BE INCLUDED THE HANDLE IN TITANIUM AND WHITE FINISH, OR PAINTED IN THE CARD COLOURS.*

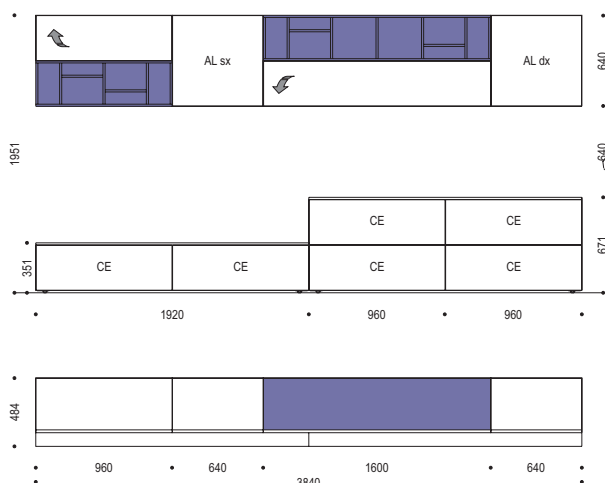

### COMPOSIZIONE | COMPOSITION II

L. 3840 H. 1951 P.|D. 484

- BASI ED ELEMENTI A TERRA P.484 lacc. lucido bianco | lacq. gloss white 9003  
FREE-STANDING BASES P.484
- RIBALTE PENSILI P.384 L.960-1600 lacc. lucido bianco | lacq. gloss white 9003  
FLAP-DOOR WALL UNITS D.384 L.960-1600
- PENSILI ANTA BATT. P.384 L.640 lacc. lucido bianco | lacq. gloss white 9003  
HINGED DOOR WALL UNITS D.384 L.640
- EL. PENSILI A GIORNO P.362 L.960-1600 lacc. lucido viola | lacq. gloss violet 4005  
OPEN WALL UNITS D.362 L.960-1600

DESIGN: Arch. Massimo Rosa - imagodesign

LA VERSATILITÀ DELLA COLLEZIONE SLIM PERMETTE DI REALIZZARE COMPOSIZIONI CAPIENTI CON UTILI CASSETTONI E PENSILI ALTERNATI A VANI GIORNO AD USO LIBRERIA.

BIANCO LUCIDO E VIOLA CONFERISCONO ELEGANZA E SOBRIETÀ A TUTTA LA COMPOSIZIONE.

APERTURA DEI FRONTALI "PUSH AND PULL".

A RICHIESTA PUÒ ESSERE INSERITA LA MANIGLIA IN FINITURA TITANIO, BIANCA O VERNICIATA COLORE A CARTELLA.

SLIM IS SO VERSATILE THAT IT COMBINES PRACTICAL DEEP DRAWER CABINETS, WALL CABINETS AND BOOKCASE SHELVES.

GLOSSY WHITE AND GLOSSY PURPLE LEND A TOUCH OF SOBER ELEGANCE TO FURNISHING COMBINATION.

FRONTS WITH "PUSH AND PULL" OPENING.

ON REQUEST CAN BE INCLUDED THE HANDLE IN TITANIUM AND WHITE FINISH, OR PAINTED IN THE CARD COLOURS.

## COMPOSIZIONI SLIM EVOLUTION | SLIM EVOLUTION COMPOSITION



### COMPOSIZIONE | COMPOSITION 47

L. 3520 H. 1850 P.|D. 484

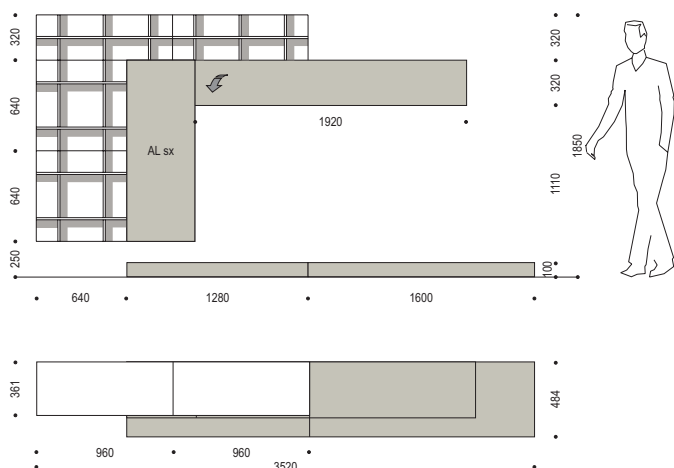

- PIANO A TERRA SP.100 resina light grey | light grey resin  
*FREE-STANDING BENCH TH.100*
- PENSILE ANTA BATTENTE P.384 L.480 resina light grey | light grey resin  
*HINGED DOOR WALL UNIT D.384 L.480*
- RIBALTA PENSILE P.384 resina light grey | light grey resin  
*FLAP-DOOR WALL UNIT D.384*
- SCAFFALATURE PENSILI P.361 lacc. opaco bianco | lacq. matt white 9003  
*MODULAR BOOKCASES WALL UNIT D.361*

DESIGN: Arch. Massimo Rosa - imagodesign

BELLA ED INNOVATIVA, LA COMPOSIZIONE FOTOGRAFATA ABBINA SAPIENTEMENTE IL LACCATO OPACO BIANCO CON LA RESINA LIGHT GREY DEGLI ELEMENTI CONTENITORI. GUSTO E RAFFINATEZZA PER UN AMBIENTE ESSENZIALE E SUGGESTIVO. LA RESINA NELLA PIACEVOLE COLORAZIONE LIGHT GREY PUO' ESSERE UTILIZZATA SIA SUGLI ELEMENTI PENSILI, SULLE BASI E SUI PANCONI AD ALTO SPESSORE. APERTURA DEI FRONTALI "PUSH AND PULL".

NICE AND INNOVATIVE, THE COMPOSITION SHOWN HERE COMBINES PERFECTLY THE WHITE MATT LACQUER WITH THE LIGHT GREY RESIN OF THE STORAGE UNITS. A REFINED TASTE FOR A MINIMAL AND SUGGESTIVE ATMOSPHERE.

LIGHT GREY RESIN CAN BE EMPLOYED EITHER ON HANGING UNITS, OR ON BASES AND THICK BENCHES. FRONTS WITH "PUSH AND PULL" OPENING.

## COMPOSIZIONI SLIM EVOLUTION | *SLIM EVOLUTION COMPOSITION*

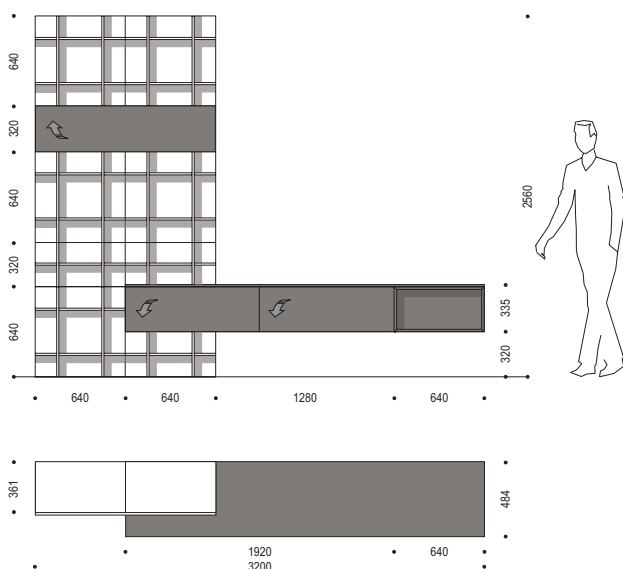

### COMPOSIZIONE | *COMPOSITION 55*

L. 3200 H. 2580 P.|D. 484

- BASI SOSPESE P.484 *SUSPENDED BASES D.484* resina dark grey | *dark grey resin*
- CUBOTTO LEGNO P.484 *WOODEN CUBE D.484* lacc. opaco dark grey | *lacq. matt dark grey*
- RIBALTA PENSILE P.384 *FLAP-DOOR WALL UNIT D.384* resina dark grey | *dark grey resin*
- SCAFFALATURE PENSILI P.361 *MODULAR BOOKCASES WALL UNIT D.361* lacc. opaco bianco | *lacq. matt white 9003*

DESIGN: Arch. Massimo Rosa - *imagodesign*

LE LIBRERIE COMPONIBILI E MODULARI LACCATE BIANCO OPACO INTEGRANO LE BASI SOSPESE REALIZZATE IN RESINA DARK GREY E COMPLETATE DAL VANO A GIORNO LACCATO IN TINTA. L'ARMONIA, IL GIOCO DEI VOLUMI E GLI ACCOSTAMENTI CROMATICI AGEVOLANO LA PROGETTAZIONE DELLA ZONA GIORNO IN UN'OTTICA DI SEMPRE MAGGIORE OTTIMIZZAZIONE DEGLI SPAZI.  
APERTURA DEI FRONTALI "PUSH AND PULL".

*COMPOUNDABLE AND MODULAR BOOKCASES IN WHITE MATT LACQUER INTEGRATE THE SUSPENDED BASES, MADE UP OF DARK GREY RESINS AND AN OPEN LACQUERED UNIT IN THE SAME COLOUR. HARMONY, THE PLAY OF VOLUMES AND CHROMATIC COMBINATIONS PERFECTLY ENHANCE THE OPTIMIZATION OF LIVING SPACE, ACHIEVED BY CONTEMPORARY DESIGN.  
FRONTS WITH "PUSH AND PULL" OPENING.*



## COMPOSIZIONI SLIM EVOLUTION | *SLIM EVOLUTION COMPOSITION*



### COMPOSIZIONE | *COMPOSITION 56 a*

L. 3840 H. 1830 P.|D. 484

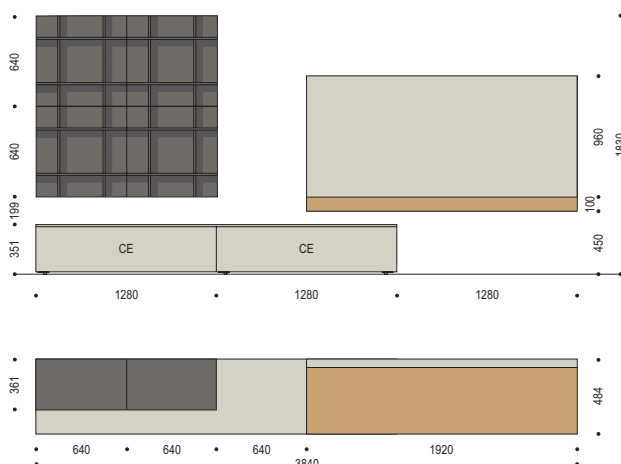

- BASI A TERRA P.484  
*FREE-STANDING BASES D.484*
- PIANO SOSPESO SP.100  
*SUSPENDED BENCH TH.100*
- BOISERIE SP.60  
*BOISERIE TH.60*
- SCAFFALATURE PENSILI P.361  
*MODULAR BOOKCASES WALL UNIT D.361*

lacc. opaco grigio seta | *lacq. matt silk grey 7044*

rovere nodi | *oak knots*

lacc. opaco grigio seta | *lacq. matt silk grey 7044*

lacc. opaco grigio aston | *lacq. matt aston grey 7039*

DESIGN: Arch. Massimo Rosa - *imagodesign*

LA CURA DEI PARTICOLARI E LA FACILITÀ DI MONTAGGIO DELLE LIBRERIE A BASSO SPESSORE INTEGRA E COMPLETA LE COMPOSIZIONI SLIM EVOLUTION. IL PANCONTE TV SOSPESO IN ROVERE NATURALE SPAZZOLATO SI ABBINA AL LACCATO CREANDO COMPOSIZIONI SEMPRE ATTUALI E VERSATILI. APERTURA DEI FRONTALI "PUSH AND PULL".

*THE CARE FOR DETAILS AND THE SIMPLE ASSEMBLY OF THESE THIN BOOKCASES INTEGRATES AND COMPLETES THE PROPOSALS OFFERED BY SLIM EVOLUTION RANGE. THE TV HANGING BENCH IN NATURAL OAK WOOD SUITS THE LACQUERED UNITS, CREATING VERSATILE COMPOSITIONS. FRONTS WITH "PUSH AND PULL" OPENING.*

## COMPOSIZIONI SLIM EVOLUTION | SLIM EVOLUTION COMPOSITION



### COMPOSIZIONE | COMPOSITION 60

L. 3840 H. 1630 P.|D. 484

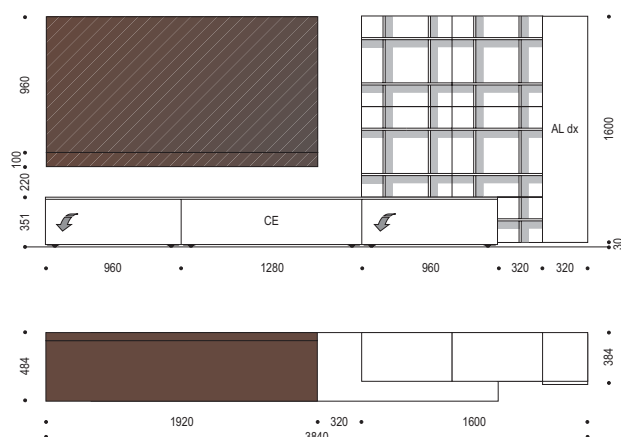

- BASI A TERRA P.484  
FREE-STANDING BASES D.484  
lacc. opaco bianco | lacq. matt white 9003
- PENSILE ANTA BATTENTE P.384 L.320  
HINGED DOOR WALL UNIT D.384 L.320  
lacc. opaco bianco | lacq. matt white 9003
- PIANO SOSPESO SP.100  
SUSPENDED BENCH TH.100  
eucalipto termotrattato | smoked eucalyptus
- BOISERIE SP.60  
BOISERIE TH.60  
eucalipto termotrattato | smoked eucalyptus
- SCAFFALATURE PENSILI P.361  
MODULAR BOOKCASES WALL UNIT D.361  
lacc. opaco bianco | lacq. matt white 9003

DESIGN: Arch. Massimo Rosa - imagodesign

LA FORTE E DECISA PERSONALITA' DELL'ESSENZA IN EUCALIPTO TERMOTRATTATO VIENE TEMPERATA DALLA LEGGEREZZA DELLA LACCATURA BIANCA E NELLO STESSO TEMPO RENDE LA COMPOSIZIONE PIU' LEGGERA ED ELEGANTE. IL LEGNO COME ELEMENTO DI TRADIZIONE E NELLO STESSO TEMPO COME MATERIALE DI FACILE ABBINAMENTO CON LA VASTA GAMMA DI LACCATI PROPOSTI, BELLA ANCHE LA VERSIONE ROVERE NODI E LACCATO BIANCO. APERTURA DEI FRONTALI "PUSH AND PULL".

THE STRONG AND DEFINITE OUTLOOK OF THERMO-TREATED EUCALYPTUS IS SOFTENED BY THE GRACE OF WHITE LACQUER: IT ADDS ELEGANCE TO THIS UNIT AND AT THE SAME TIME LIGHTENS IT.

WOOD: THE SIGN OF TRADITION AND A VERSATILE MATERIAL, THAT SUITS ANY LACQUER AVAILABLE. BEAUTIFUL INSTEAD IN THE VERSION OAK KNOTS AND WHITE LACQUER. FRONTS WITH "PUSH AND PULL" OPENING.

## COMPOSIZIONI SLIM EVOLUTION | SLIM EVOLUTION COMPOSITION



### COMPOSIZIONE | COMPOSITION 62

L. 3840 H. 2350 P.|D. 484

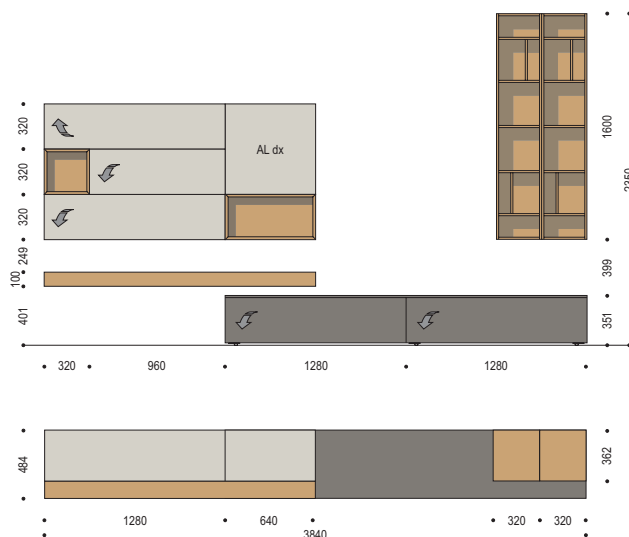

- BASI A TERRA P.484 resina dark grey | dark grey resin  
*FREE-STANDING BASES D.484*
- PIANO SOSPESO SP.100 rovere nodi | oak knots  
*SUSPENDED BENCH TH.100*
- PENSILE ANTA BATTENTE P.384 L.640 lacc. opaco grigio perla | lacq. matt pearl grey 238  
*HINGED DOOR WALL UNIT D.384 L.640*
- RIBALTE PENSILI P.384 lacc. opaco grigio perla | lacq. matt pearl grey 238  
*FLAP-DOOR WALL UNITS D.384*
- CUBOTTI LEGNO P.362 rovere nodi | oak knots  
*WOODEN CUBES D.362*
- EL. PENSILI A GIORNO P.362 rovere nodi | oak knots  
*OPEN WALL UNITS D.362*

DESIGN: Arch. Massimo Rosa - imagedesign

SLIM EVOLUTION DA LA POSSIBILITA' DI ABBINARE I VARI LACCATI OPACHI E LUCIDI CON LE NUOVE RESINE E LE NUOVE ESSENZE. GRIGIO PERLA E ROVERE NATURALE SPAZZOLATO PER AMBIENTI CARATTERIZZATI DA UNA FORTE PERSONALITA' E DA UN INDISCUTIBILE CARISMA. APERTURA DEI FRONTALI "PUSH AND PULL".

SLIM EVOLUTION GIVES US THE POSSIBILITY OF COMBINING THE SEVERAL MATT AND GLOSSY LACQUERS WITH THE NEW RESINS AND FINISHES. PEARL GREY AND NATURAL OAK WOOD FOR AMBIANCES CHARACTERIZED BY A STRONG PERSONALITY, AND UNQUESTIONABLE CHARM. FRONTS WITH "PUSH AND PULL" OPENING.

## COMPOSIZIONI SLIM EVOLUTION | *SLIM EVOLUTION COMPOSITION*

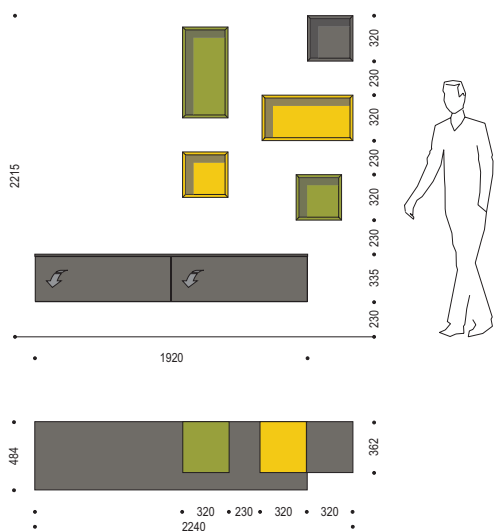

### COMPOSIZIONE | *COMPOSITION 68*

L. 2240 H. 2215 P./D. 484

- BASI SOSPESSE P.484  
*SUSPENDED BASES D.484*

- CUBOTTO LEGNO P.362  
*WOODEN CUBES D.362*

lacc. opaco grigio aston | *lacq. matt aston grey 7039*

lacc. opaco grigio aston | *lacq. matt aston grey 7039*  
lacc. o. verde pompelmo | *lacq. matt grapefruit green 192*  
lacc. opaco giallo cromo | *lacq. matt chrome yellow 140*

DESIGN: Arch. Massimo Rosa - *imagodesign*

ELEMENTI "CUBOTTI" LACCATO OPACO ASTON, OPACO POMPELMO E OPACO GIALLO CROMO IN APPARENTE ORDINE SPARSO, POSIZIONATI SOPRA UNA CAPIENTE BASE CON ANTE A RIBALTA.  
APERTURA DEI FRONTALI "PUSH AND PULL".

*SCATTERED "CUBES" IN ASTON GREY MATT LACQUER, MATT GRAPEFRUIT GREEN AND CHROME YELLOW, POSITIONED ON A WIDE BASE UNIT WITH FLAP DOORS.  
FRONTS WITH "PUSH AND PULL" OPENING.*

## GAMMA COLORI | COLOUR RANGE

### ESSENZE | WOODS



rovere moro  
oak in mahogany finish



noce canaletto  
black American walnut



rovere nodi \*\*  
oak knots



eucalipto termotrattato \*\*  
smoked eucalyptus

\*\* solo per alcuni elementi  
only for some elements

### TELAI ANTE VETRO BATTENTI E A RIBALTA | FRAMES FOR HINGED AND FLAP GLASS DOORS

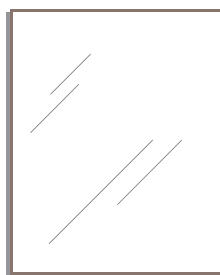

finitura brunito  
burnished finish

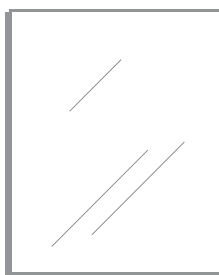

finitura alluminio  
aluminium finish

### VETRI | GLASSES

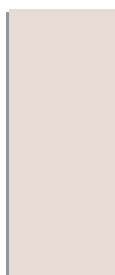

sabbia chiaro (cat.1)  
light sand

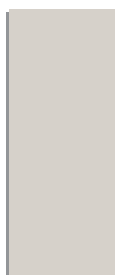

sabbia scuro (cat.1)  
dark sand



corda (cat.1)  
rope



grigio pietra (cat.1)  
stone grey



grigio chiaro (cat.1)  
light grey



grigio medio (cat.1)  
medium grey



grigio polvere (cat.1)  
powder grey



blu piombo (cat.1)  
gun metal blue



giallo cromo (cat.1)  
chrome yellow



verde pompelmo (cat.1)  
grapefruit green



rosso rubino (cat.1)  
ruby red



nero (cat.1)  
black



\* stopsol fumé (cat.1)  
smoke-grey stopsol



specchio (cat.1)  
mirror



specchio bronzo (cat.1)  
bronze mirror

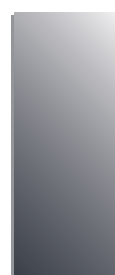

specchio fumo (cat.1)  
smoke mirror



\* trasparente (cat.1)  
transparent



bianco (cat.2)  
white



magnolia (cat.2)

\* ATTENZIONE: i vetri stopsol fumé e trasparente lasciano intravedere il telaio sottostante | ATTENTION: the smoke-grey stopsol and transparent glasses allow a glimpse of the underlying frame

## GAMMA COLORI | COLOUR RANGE

### LACCATI OPACHI E LUCIDI | MATT AND GLOSSY LACQUERS

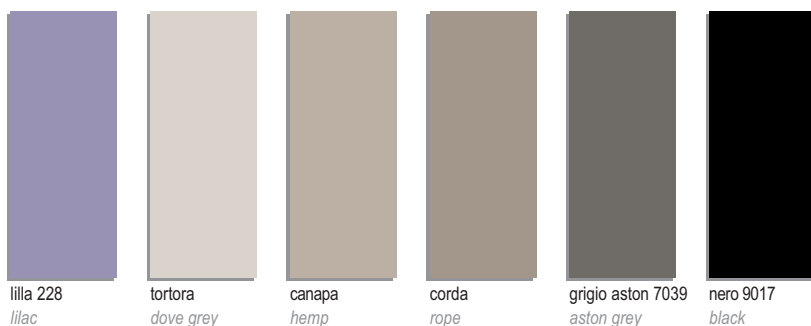
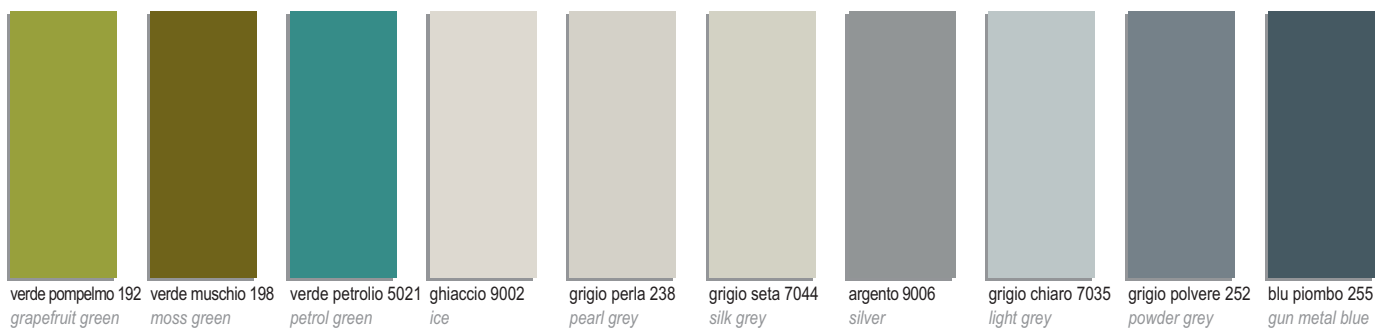
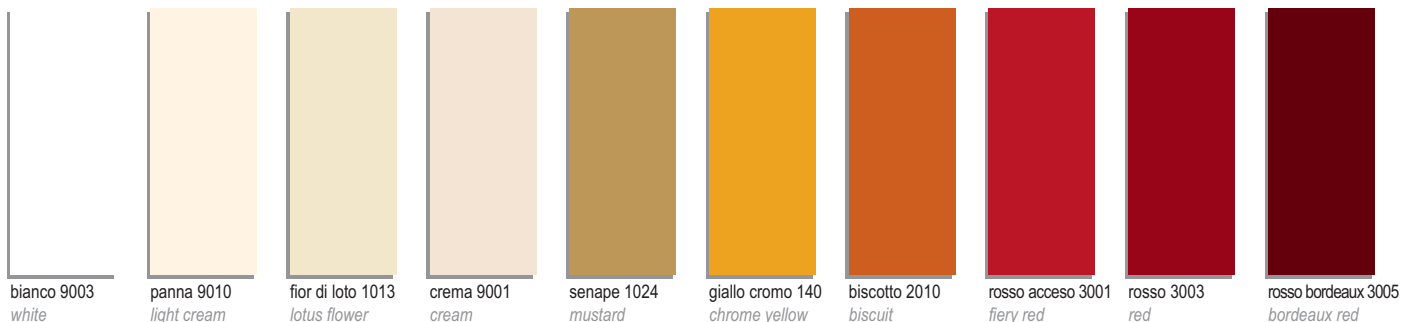

### RESINE | RESINS

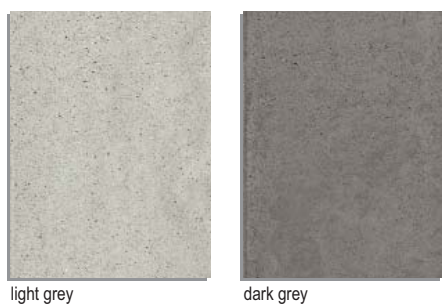

### LACCATI OPACHI | MATT LACQUERS

per interni ed elementi abbinati alla resina | *per interni ed elementi abbinati alla resina*

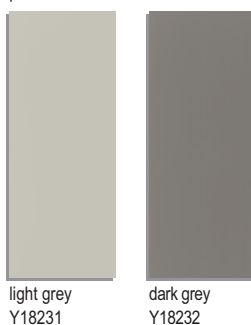

N.B.: La riproduzione dei colori su carta può risultare alterata rispetto agli originali, pertanto queste tinte sono da considerarsi puramente indicative.

*N.B.: The reproduction of the colours on paper may be different with respect to the original colours, therefore these shades should be considered representative only.*