

AlfaOmega

COLLECTION

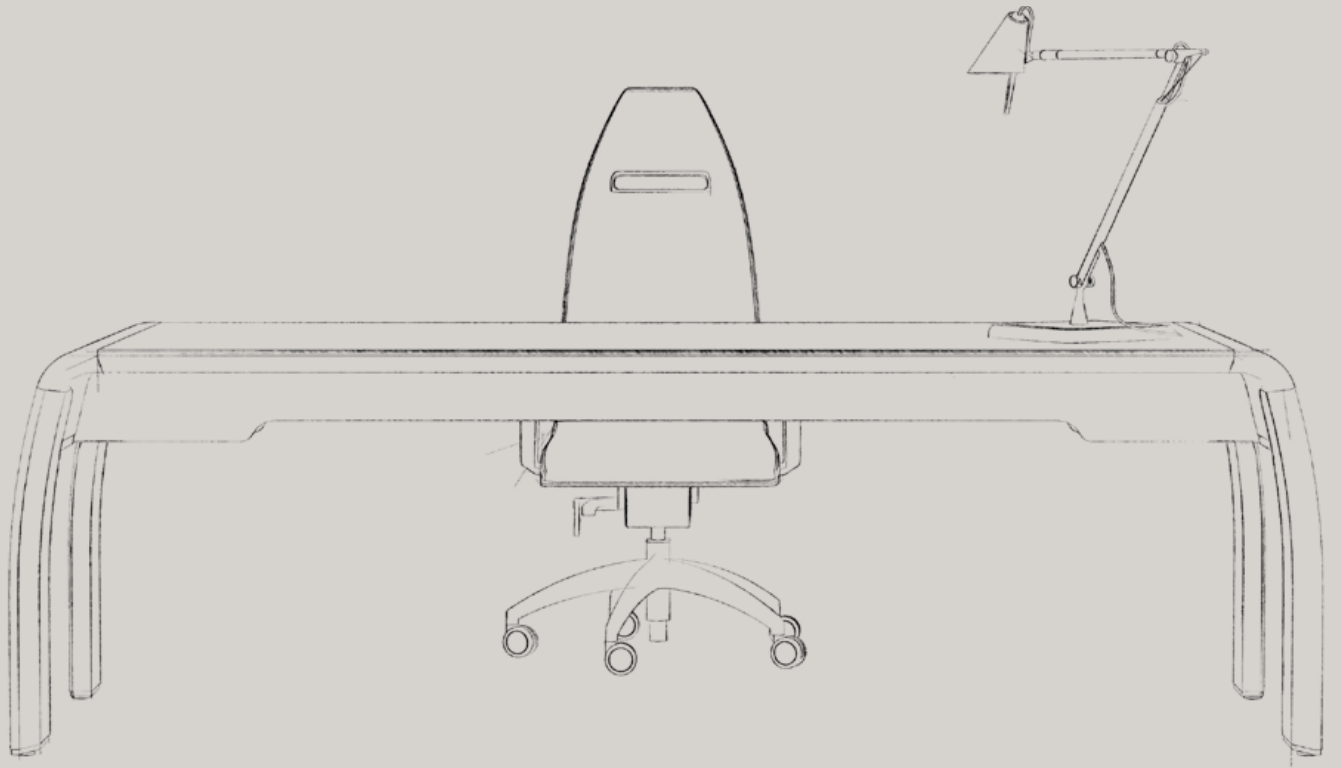

Noi di Codutti,
dal 1954 artigiani ed industriali insieme,
creiamo arredi di design
e progettiamo soluzioni uniche
per darti l'ufficio Made in Italy
che ti emoziona ogni giorno.

Since 1954, here at Codutti
we have been both craftsmen and industrialists;
we create design furniture
and find unique solutions
to give you a Made in Italy office
that will thrill you day after day.

AlfaOmega
COLLECTION

DESIGN
Sergio Codutti

AlfaOmega
COLLECTION

DESIGN
BECOME
HI-TECH

Noi di Codutti avevamo un'idea impossibile, cullata da lungo tempo: volevamo creare qualcosa che sapesse suscitare la stessa emozione in individui di natura profondamente diversa.

Dai nostri sogni è nata AlfaOmega, due anime e un tratto curvo che sottende una stessa idea di design.

Alfa è per chi ama un ambiente hi-tech, futurista e innovativo; Omega è per chi preferisce l'eleganza dai canoni classici, bellezza senza tempo. Dentro AlfaOmega pulsa Soundoffice, un cuore multimediale che da voce alla scrivania e la trasforma nell'oggetto del desiderio di chi ama la tecnologia e l'eccellenza del miglior made in italy.

For a long time, we at Codutti have had an impossible idea: to create something able to arouse the same emotion in people of very different nature.

From our dreams comes AlfaOmega, two spirits and a curved section behind the same design idea.

Alfa is for anyone in love with a hi-tech, futurist and innovative interior; Omega is for those who prefer a more classic elegance and timeless beauty. Inside AlfaOmega beats Sound Office, a multimedia heart that gives voice to the desk and transforms it into an object of desire for technology buffs with all the excellence of the very best of made in Italy.





A L F A

Tecnologia, dal greco "discorso sull'arte": a ricordarci che i dispositivi che faciliteranno il nostro avvenire non potranno prescindere dal fascino del design. Alfa è la declinazione hi-tech di AlfaOmega. Qui la luce accende dettagli cromati, mentre l'ombra sottolinea morbide curve: piani in vetro ultrachiaro verniciati, curve e sottopiani in laccato lucido, gambe e accessori rivestiti in cuoio materico nelle moderne texture bugnato o carbonio. Bianco, nero, biancoenero: colori decisi per chi vuole sentire in ogni momento l'emozione del controllo.

Technology, from the Ancient Greek "discourse on art": to remind us that the devices, that will make our future easier, cannot disregard design appeal. Alfa is the hi-tech declination of AlfaOmega. Here light highlights chromed details, while shadows underscore soft curves: lacquered extra-clear glass tops, gloss lacquered curves and under-tops, legs and accessories covered in tactile thick leather in modern embossed or carbon textures. White, black, black&white: strong colours for those who want to feel the thrill of control at all times.



Dati tecnici/Technical Data

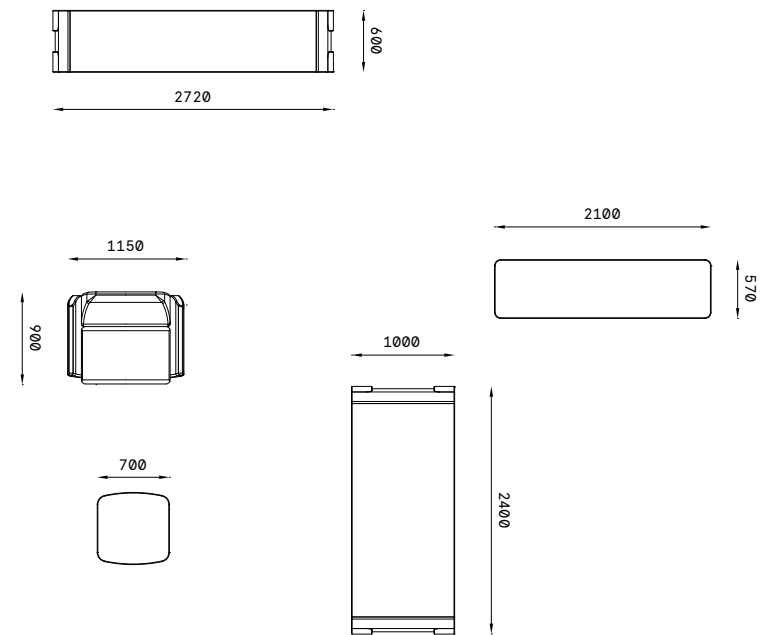

Finiture/Finishes

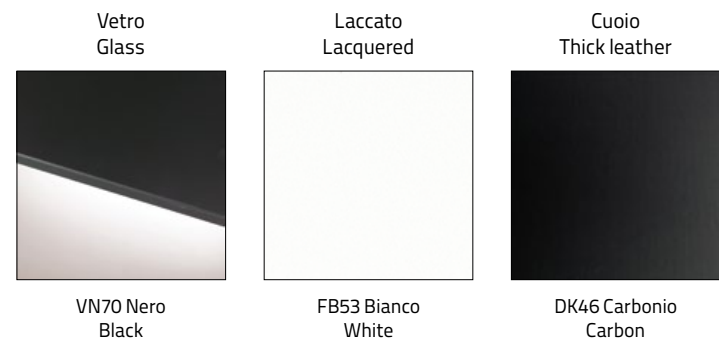

+ Il rivestimento in cuoio delle gambe Alfa non richiede l'utilizzo di cuciture; un filo luce cromato supporta i piedini regolabili.
The thick leather upholstery of the Alfa legs does not require the use of stitches; a chrome-plated flush band supports the adjustable feet.

+ Allungo indipendente attrezzabile: può contenere 4 moduli a scelta tra armadietto e coppia cassetti.
Equipped independent extension: can contain a choice of 4 modules – small cabinet and pair of drawers.

+ Ante complanari a scorrimento incrociato con sistema di chiusura ammortizzata e illuminazione interna opzionale.
Parallel crossover sliding doors featuring dampened closing system and optional internal lighting.



ALFA



Dati tecnici/Technical Data

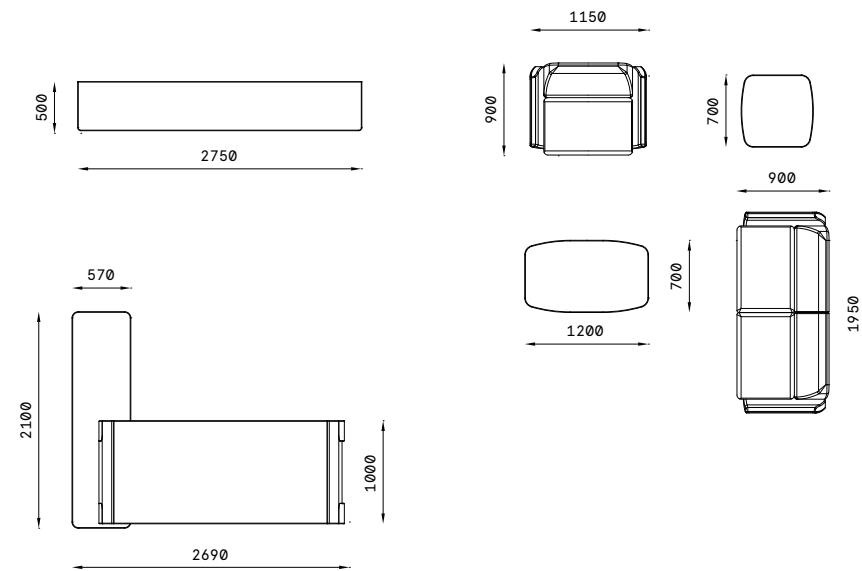

Finiture/Finishes

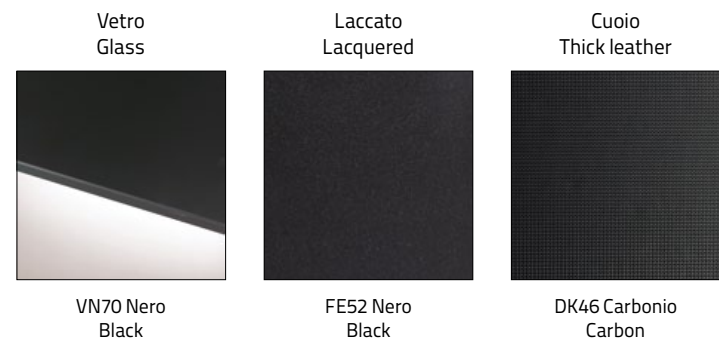

+ È possibile personalizzare la seduta con l'inserimento del logo lavorato a ricamo sullo schienale.
The seats can be personalized by means of the embroidered-finish logo on the back.

+ Incavo e profilo perimetrale possono essere in tinta o in contrasto con il colore di rivestimento della seduta.
Back hollow and profile edge can be in the same or contrasting colour with that of the seat upholstery.

+ Design e pelle forata: Coupè si ispira ai sedili delle gloriose auto sportive del passato.
Open work thin leather and design: Coupè is inspired by the seats of the glorious sports cars of the past.



Scrigno di AlfaOmega/AlfaOmega treasure chest



Le lavorazioni eseguite in modo magistrale dai nostri artigiani e il numero di serie, fanno di ogni scrivania e tavolo riunione AlfaOmega un pezzo unico al mondo. Per i clienti che scelgono questa collezione abbiamo creato Lo Scrigno di Alfaomega, un cofanetto che contiene il kit di pulizia e di ritocco per mantenere inalterata nel tempo la bellezza dei nostri arredi. Nel cofanetto, un nostro regalo: il portadocumenti in cuoio realizzato a mano che contiene il Certificato di Autenticità del vostro ufficio AlfaOmega.

The finishes created by the skilful hands of our craftsmen and the serial number, ensure that each AlfaOmega writing desk and meeting table is truly one of a kind in the world. For the customers who choose this collection, we have created the AlfaOmega Treasure Chest, a casket containing a cleaning and touch-up kit to keep our furnishings looking beautiful over the years. Inside the casket, a gift from us, you will find a handmade leather document holder containing the Certificate of Authenticity of your AlfaOmega office.







+ I cassetti hanno chiusura soft, il fondo rivestito in cuoio e la serratura opzionale con chiave rivestita in cuoio.
The drawers feature soft closing, the bottoms are covered in thick leather and the optional lock features a leather-covered key.

+ Mobiletto attrezzabile: può contenere 2 moduli a scelta tra armadietto e coppia cassetti.
Extension element that can contain a choice of 2 modules – small cabinet and pair of drawers.

Dati tecnici/Technical Data

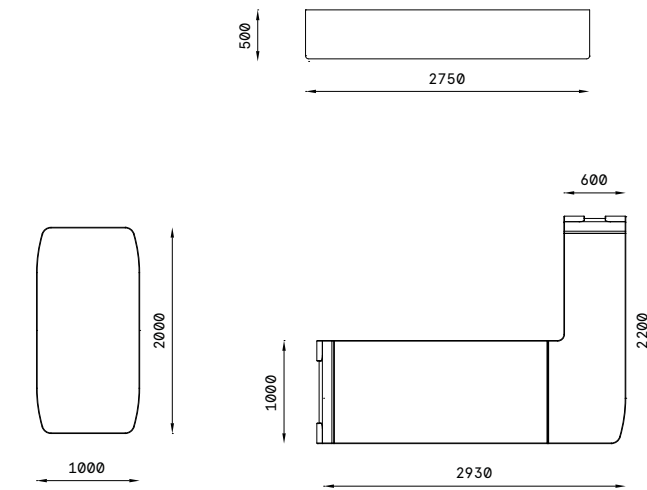

+ Sottopiani laccati in finitura lucida bianca o nera.
Under-tops are lacquered in white or black gloss finish.

Finiture/Finishes





A L F A



Dati tecnici/Technical Data

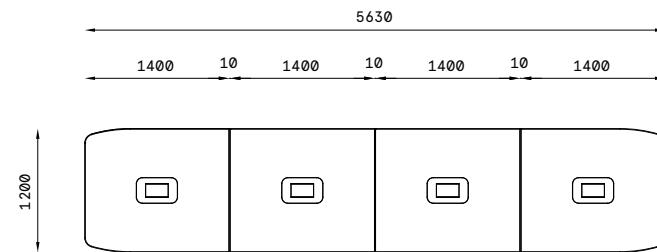

Finiture/Finishes

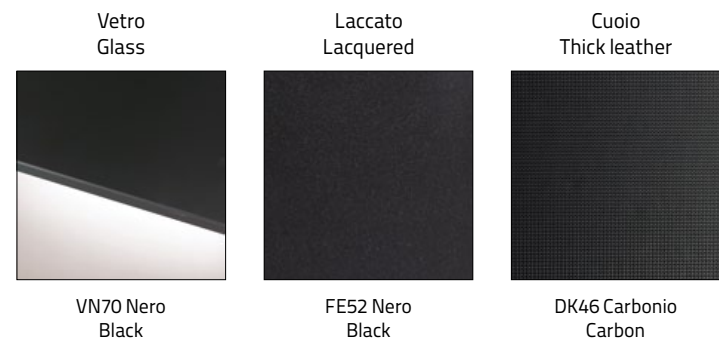

+ La forma stondata dello spessore del top è data dall'unione della superficie in vetro con il sottopiano laccato in finitura gloss.
The rounded shape of the top thickness is produced by the union of the glass surface and the gloss-finish lacquered under-top.

+ La gamba a colonna è l'unione di due gusci rivestiti in cuoio che lasciano scoperto l'inserito laccato.
The column leg is the union of two thick leather-covered shells which leave the lacquered insert uncovered.





codutti

AlfaOmega#Omega

OMEGA

Qui si parla di sogni, di design, di materiali pregiati; ma anche di atmosfera, di enfasi, di misura dell'ambiente che ci circonda.

Omega è la declinazione elegante di Alfaomega.

Lo si intuisce dalla attenta selezione delle essenze di legno, rovere tinto ebano e tinto noce, le cui venature si intrecciano in piani e curve; dal raffinato inserimento del vetro nero; dall'utilizzo di cuoi esclusivi come il vinaccia, il nuovo millemiglia e la tecnologica superficie che permette a uno strato di vera pietra ardesia di essere lavorata come fosse cuoio.

This is a story of dreams, design and top-quality materials; but also atmospheres, emphasis and measurement of the environment that surrounds us.

Omega is the elegant declination of Alfaomega.

This can be seen in the careful selection of woods, ebony and walnut dyed oak, the grains of which intertwine in tops and curves; in the refined insertion of black glass; in the use of exclusive thick leathers such as plum red colour, the new millemiglia and the technologic surface which enables a layer of real slate to be worked as if it were leather.



Dati tecnici/Technical Data

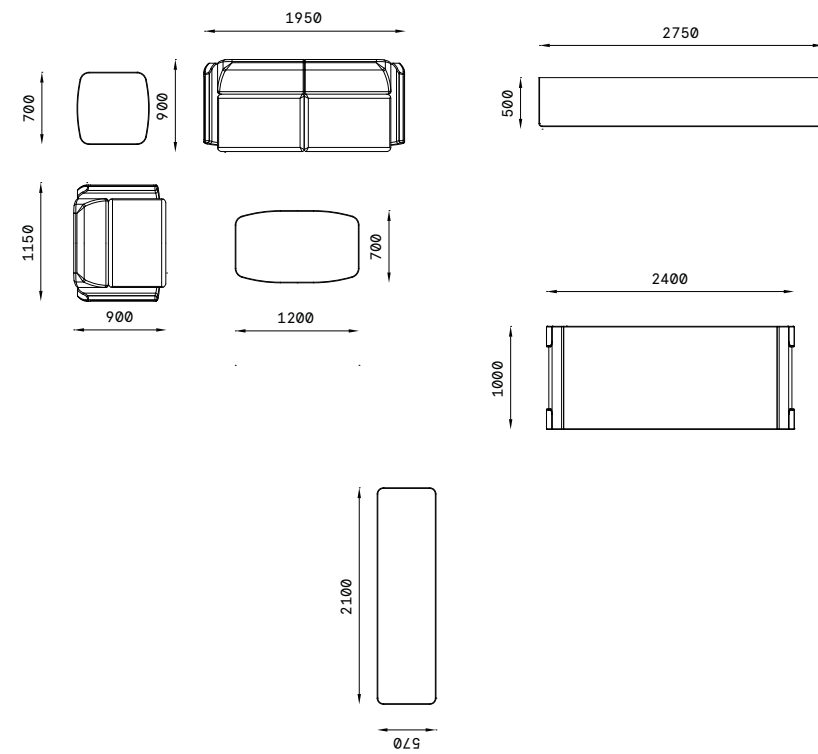

Finiture/Finishes

Legno Wood	Laccato Lacquered	Cuoio Thick leather
		
SH11 Ebano Ebony	FE52 Nero Black	DM45 Millemiglia



Le gambe Omega sono rivestite in cuoio cucito a mano nel caratteristico punto sella.

The Omega legs are covered in thick leather, saddle-stitched by hand.



Le curve di raccordo si distinguono dal top per l'incrocio delle venature del legno.

What makes the connection curves different from the top are the crossed-over wood grains.



O M E G A

Dati tecnici/Technical Data

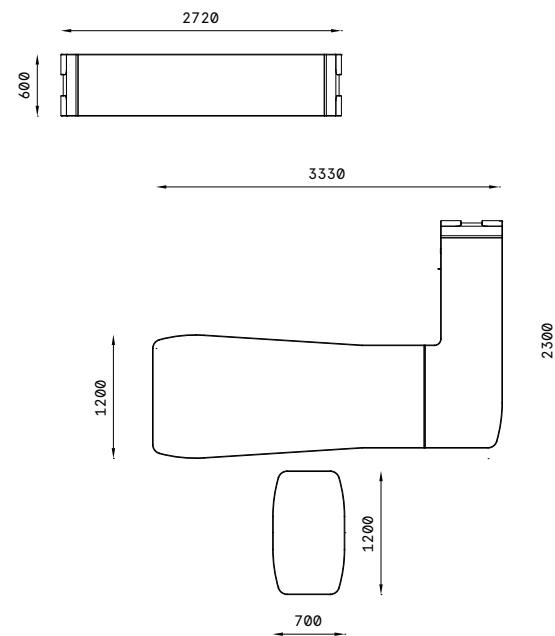

Finiture/Finishes



+ Un vero microstrato di pietra ardesia avvolge, docile e materico, arredi ed accessori.
A real micro-layer of slate stones envelops furnishings and accessories, docile and tactile.

+ Piccole, anatomiche, preziose: queste sono le maniglie AlfaOmega in acciaio cromato.
Small, anatomic, precious: these are the AlfaOmega handles in chrome-plated steel.



+ Tavoli riunione di forme, dimensioni e finiture personalizzate: l'ufficio tecnico Codutti è a disposizione per realizzare le vostre idee.

Meeting tables with personalized shapes, dimensions and finishes: the Codutti technical department is at disposal to put your ideas into practice.

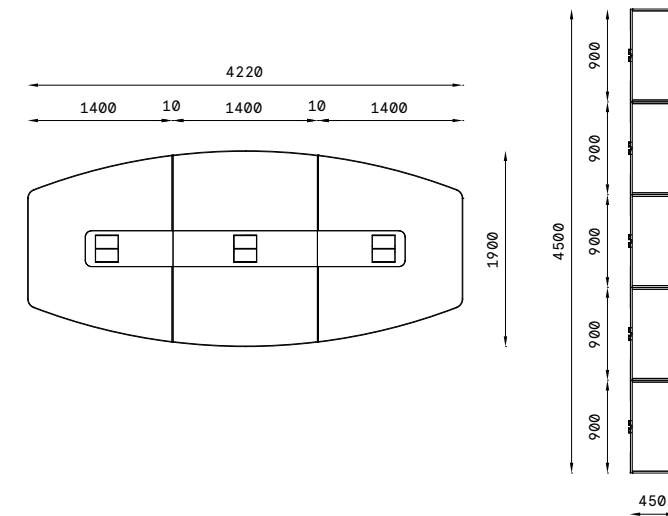

Dati tecnici/Technical Data



+ Fascia tecnica centrale in cuoio con sportellini bilaterali per la fuoriuscita dei cavi.
Central thick leather band with bilateral doors for the cables to come out.

Finiture/Finishes





Le cuciture a punto sella sono il risultato della maestria dei nostri artigiani che eseguono le lavorazioni manualmente.

The saddle stitching is the upshot of the skill of our craftsmen and is all handmade.



Tavolo componibile: i moduli del piano sono separati da un filo luce in acciaio cromato.

Modular table: the top modules are separated by a chrome-plated flush band.





codutti

AlfaOmega#Omega

Dati tecnici/Technical Data

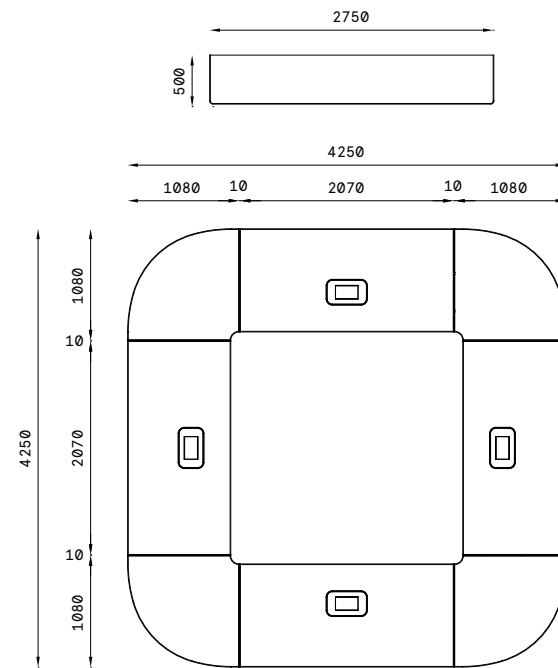

Finiture/Finishes



- + All'interno degli sportellini possono essere collocate apposite prese multifunzione.
Special multifunction sockets can be placed inside the doors.
- + L'alzamonitor consente di alzare, abbassare, ruotare in avanti e indietro gli schermi. Il controllo può essere manuale, remoto o centralizzato.
The screen lifting mechanism permits raising, lowering and turning the screens backwards and forwards. Control is manual, remote or centralized.



- + Elemento di testa per tavolo riunione componibile in conformazione a "U".
Head element for modular U-shaped meeting table.





+ Lo schienale del pulpito prevede di serie una canalizzazione per il passaggio dei cavi.
The back of the pulpit features a cables duct as standard equipment.

+ La lavorazione ad intarsio cuoio su cuoio consente la massima personalizzazione delle parti rivestite tramite l'inserimento di scritte o logos.
The inlaid leather-on-leather process ensures utmost personalization of the covered parts by insertion of lettering or logos.

Dati tecnici/Technical Data

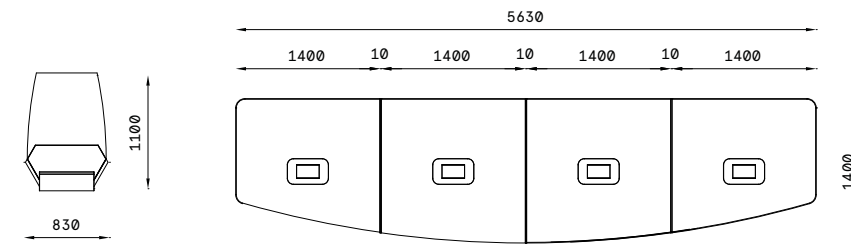

Finiture/Finishes

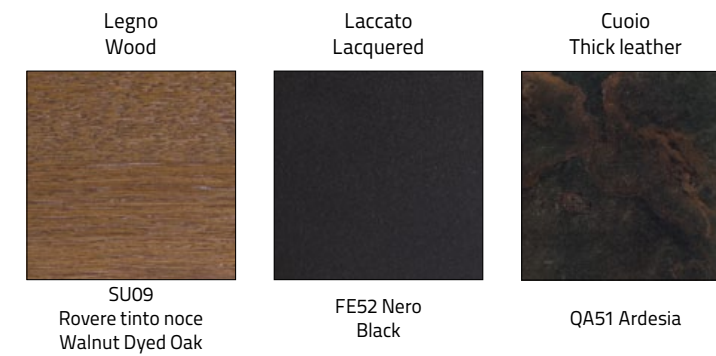

Choose your Music Style

CODUTTI SOUND OFFICE
the hi-fi writing desk

Scopri Codutti Sound Office!
Fotografa col tuo smartphone
il codice QR e goditi il video
che Codutti ha realizzato per te.

Shoot with your smartphone the
QR code below and enjoy the video
that Codutti made for you.



Il potere della musica, il genio della musica,
il sogno della musica; sgorgano come per magia dal
cuore vibrante della scrivania, invadono l'ambiente,
incantano noi stessi e s'impossessano di tutto.

The power of music, the genius of music,
the dream of music; these all bubble up magically
from the beating heart of this desk, to invade the
atmosphere, enchanting us, taking possession.

+ Controlli/ Controls

Una gestione facile e intuitiva dei comandi consente le regolazioni dei volumi, la risposta alle chiamate in arrivo e l'interazione di Soundoffice con i dispositivi multimediali. Questi ultimi si possono connettere alla scrivania attraverso il cavo Audio Mini- Jack o attraverso il protocollo di comunicazione senza fili Bluetooth.

Easy-to-adjust and intuitive controls for regulating volumes, incoming call answering and Soundoffice interaction with multi-media devices. The latter can be connected to the writing desk by means of the Audio Mini- Jack lead or through the communication protocol without Bluetooth wires.



+ Casse acustiche/ Loudspeakers

Il suono ricco e dettagliato sembra provenire dalle pareti, dal soffitto, dal pavimento, pervade l'ambiente e rapisce con sonorità coinvolgenti. I diffusori, che alloggiato sotto al piano, si trovano nella posizione ottimale per l'ascolto da parte di chi siede alla scrivania.

- Casse acustiche con potenza nominale di 20W a 8 ohm e risposta di 95-22.000 Hz
- Amplificatore stereo hi-fi con frequenze tra i 20 e 20.000Hz

The rich and detailed sound seems to come from the walls, the ceiling, the floor and pervades the environment and enraptures with fascinating sound effects. The speakers, housed under the top, are perfectly positioned for listening by anyone sat at the desk.

- Loudspeakers with 20W nominal power at 8 ohm and 95-22.000 Hz response.
- Stereo hi-fi amplifier with frequency between 20 and 20.000Hz.

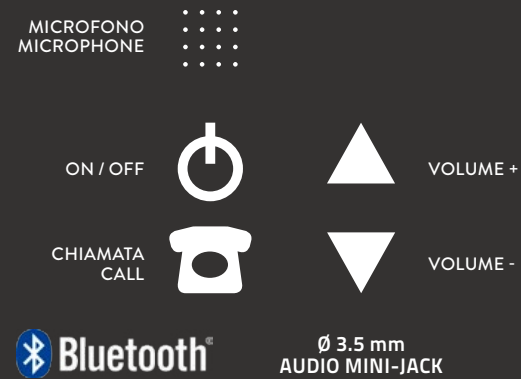

+ Canalizzazione/ Ducting

I cavi che alimentano Soundoffice transitano dal vano di diffusione alla canalizzazione posta tra le due traverse, per poi scendere a terra attraverso un elegante contenitore accoppiato alla gamba della scrivania, rivestito in cuoio o nell'esclusiva pietra.

The Soundoffice power leads transit from the speaker compartment to the ducts located between the two crosspieces, then they run down to the floor through an elegant container placed on a leg of the writing desk and covered in leather or exclusive stone.



Scrivania o cabina di regia? Scrivania o cassa armonica? Lavorare telefonando senza il dispositivo in mano o rilassarsi ascoltando musica in Hi-Fi? Tutto questo è Soundoffice.

Writing desk or control room? Writing desk or soundbox? Working on the phone without having to hold it in your hand or relaxing while listening to Hi-Fi music? All this is Soundoffice.

+ Controlli/Controls



+ Casse acustiche/Loudspeakers

+ Canalizzazione/Ducting

Rainbow

I colori ed i loro abbinamenti esprimono chi sei. Poterli scegliere significa trovare la libertà di esprimersi e l'occasione di trasmettere un messaggio a chi ci circonda. Rainbow è il progetto che permette di personalizzare il colore di ogni collezione scegliendo tra le numerose finiture di cuoio previste nel Campionario Finiture Codutti.

The colours and the way they are matched tell who you are. Being able to choose them means having the freedom to express yourself and the chance to send a message to those around us. Rainbow is the project which permits personalizing the colour of every collection, choosing from among the numerous leather finishes in the Codutti Sample Book.

FINITURE CUOIO / THICK LEATHER FINISHES



AlfaOmega Accessori/Accessories



Alfa

SCRIVANIE CON TOP LEGNO
WOOD TOP WRITING DESK

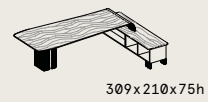
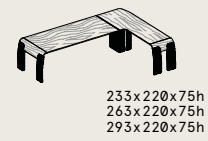
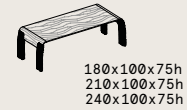

SCRIVANIE CON TOP VETRO
GLASS TOP WRITING DESK

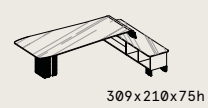
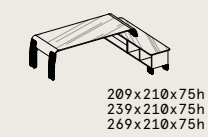
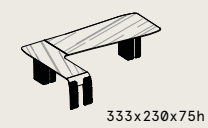
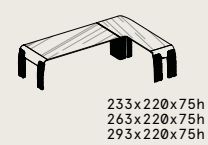
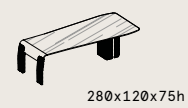
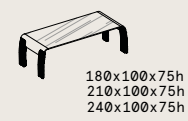

ALLUNGHII LEGNO
WOOD EXTENSIONS

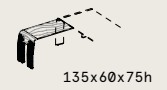

ALLUNGHII VETRO
GLASS EXTENSIONS

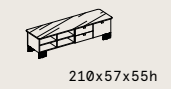

CASSETTIERE
DRAWER UNITS



TAVOLINI ATTESA
SIDE TABLES



PULPITO
PULPIT



LIBRERIE CON TOP LEGNO
WOOD TOP BOOKCASES

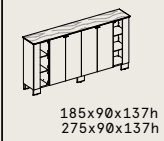
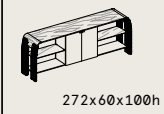
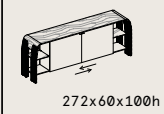

LIBRERIE CON TOP VETRO
GLASS TOP BOOKCASES

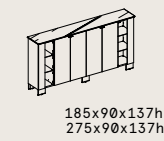
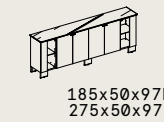
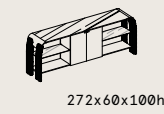
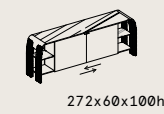

Omega

TAVOLI RIUNIONE CON TOP LEGNO
WOOD TOP MEETING TABLES

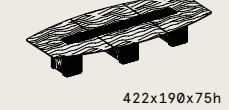

TAVOLI RIUNIONE E CONFERENZA CON TOP VETRO
GLASS TOP MEETING AND CONFERENCE TABLES

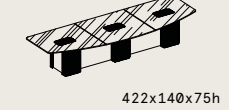
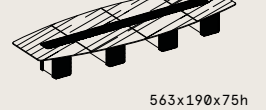
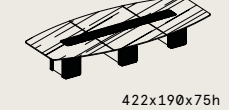
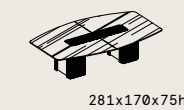
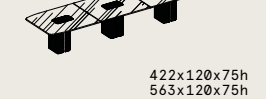
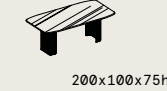

ARMADI
CABINETS

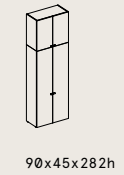
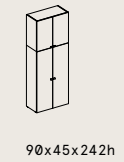
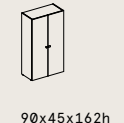
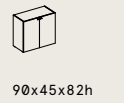

Images

Grafiche Filacorda
Cesare Bellafronte

Print

Grafiche Filacorda/Italy
march 2015

Copyright© 2015
by Codutti S.p.A.



Codutti S.p.A.

Via Bonavilla, 24
33037 Pasian di Prato
Fr. Passons (UD) ITALIA
Tel. +39 0432 541414
Fax +39 0432 540045
codutti@codutti.it
www.codutti.it



