

## Inciso

design Enzo Berti

### Description

The subtle game on the inversion of the volumetric criterions, whereby the structure is lighter and the density and the volume of the top are increased, makes “Inciso” an innovative project. Designed for large spaces, “Inciso” has an unexpected choice of unusual materials: a thin layer of aluminium which carves the space with great personality and strength.

### Specifiche Tecniche

Rectangular extensible table with aluminum rails.

### Dimensions (LxPxH)

- Closed 240x90x76 cm
- Open 400x90x76 cm

### Finishings

Cod 01; Cod 02; Cod 03; Cod 04; Cod 05; Cod 06; Cod 07; Cod 08; Cod 09

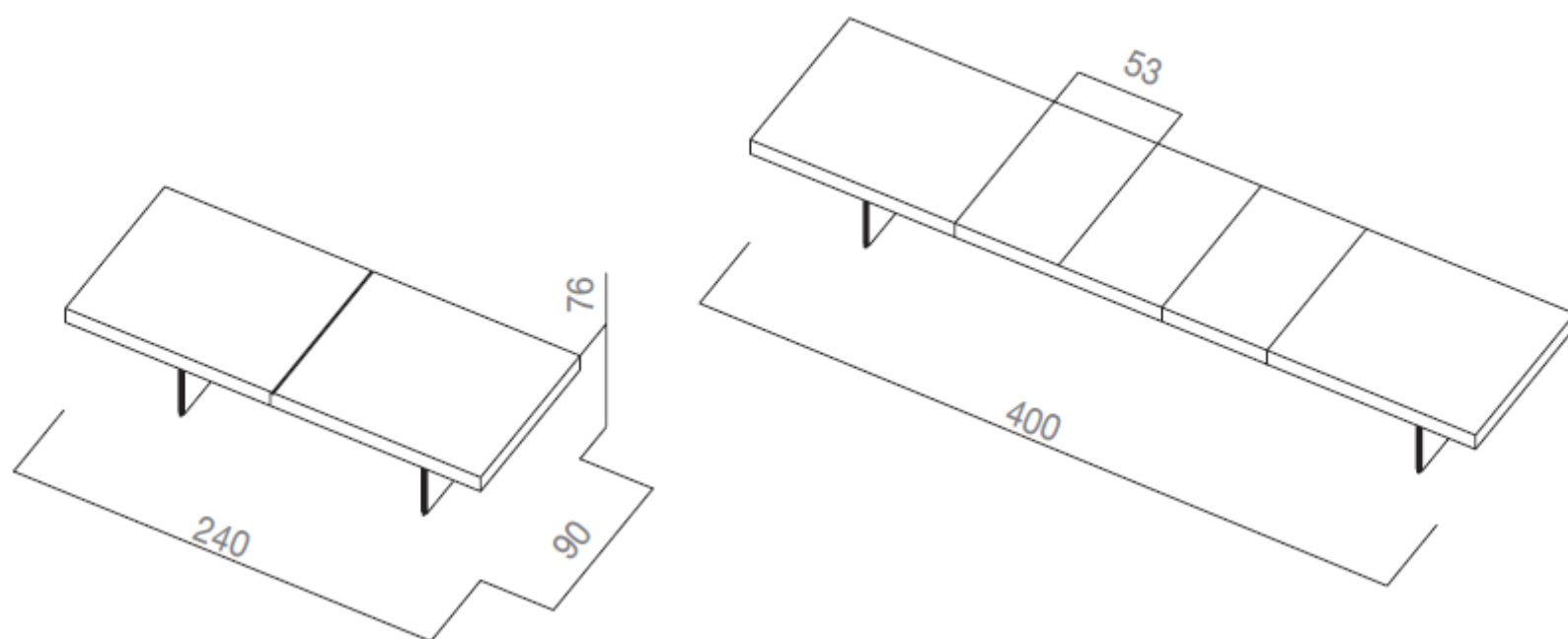



Cod. 01 - Frassino o Rovere  
Cod. 01 - Ash or Oak



Cod. 05 - Frassino o Rovere  
Cod. 05 - Ash or Oak



Cod. 09 - Bianco  
Cod. 09 - White



Cod. 02 - Frassino sbiancato  
Cod. 02 - Light Ash



Cod. 06 - Rovere sbiancato  
Cod. 06 - Light Oak



Cod. 10 - Ciliegio  
Cod. 10 - Cherry



Cod. 13 - Faggio  
Cod. 13 - Beech



Cod. 03 - Frassino o Rovere  
Cod. 03 - Ash or Oak



Cod. 07 - Rovere naturale  
Cod. 07 - Natural Oak



Cod. 11 - Ciliegio  
Cod. 11 - Cherry



Cod. 14 - Faggio  
Cod. 14 - Beech



Cod. 04 - Frassino o Rovere  
Cod. 04 - Ash or Oak



Cod. 08 - Frassino o Rovere  
Cod. 08 - Ash or Oak



Cod. 12 - Ciliegio  
Cod. 12 - Cherry



Cod. 15 - Faggio  
Cod. 15 - Beech

I colori del campionario sono puramente indicativi e sono possibili differenze di tonalità tra una partita di produzione e l'altra. Il legno è un prodotto naturale: baffi, nodi, variazioni di colore e di poro sono le esclusive prove della sua naturale bellezza.

All sample colours are merely indicative and there may be differences in shade between one production lot and the another. Wood is a natural product: Any patches, knots, porous and shade variations are an exclusive proof of its natural beauty.